



NorthPass – Promotion of the Very low-energy house
Concept to the North European Building Market

26/05/2009 - 25/05/2012

Principles of low-energy houses applicable in North European countries and their applicability throughout the EU

30.12.2010

Passivhus.dk

Disclaimer

The information in this document is provided as is and no guarantee or warranty is given that the information is fit for any particular purpose. The user thereof uses the information at its sole risk and liability.

The sole responsibility for the content of this publication lies with the authors. It does not necessarily reflect the opinion of the European Communities. The European Commission is not responsible for any use that may be made of the information contained therein.

Table of contents

1	Executive summary	4
2	Introduction	5
3	The principles of a very low energy house – in general in climates dominated by heating demand	6
3.1	Minimize losses by the building envelope.....	8
3.1.1	Building form and compactness	9
3.1.2	Opaque building envelope and thermal bridges.....	10
3.1.3	Windows and the installation of them	16
	Air tightness of the thermal envelope.....	18
3.2	Minimize losses by the building system.....	19
3.2.1	Ventilation heat recovery	19
3.2.2	Insulation of heat distribution	21
3.3	Maximizing gains by the building envelope	22
3.3.1	Orientation of the building	22
3.3.2	The optimal window glass.....	24
3.4	Maximizing/using environmental gains by the building system	25
3.4.1	Building control system	25
3.4.2	Thermal solar panels and photovoltaics	26
3.4.3	Heat from ground / Geothermal energy (anergy)	27
4	Special conditions in the Northern Europe.....	29
4.1	North European Climate.....	29
4.1.1	Exterior temperatures	30
4.1.2	Solar radiation	31
4.1.3	Freezing of ground	33
4.1.4	Freezing of heat recovery	34
4.2	Building traditions.....	36
4.3	Strength of economy	37
5	Influence of the special conditions on the building design	40
5.1	The building envelope and energy.....	40
5.1.1	Building envelope	40
5.1.2	Window as loss and gain-factor	43
5.1.3	Interior surface temperatures	45
5.2	Solving the specific challenges in colder climates	46
5.2.1	Freezing of heat recovery	46
5.2.2	Limited potential for heating by supply air.....	48
5.2.3	Freezing of ground	48
5.2.4	Summer situation.....	51
5.2.5	Electrical appliance.....	51
5.3	Strength of economy, price of buildings.....	52
6	Summary of the Principles for very low energy buildings in the Northern Europe.....	53
6.1	Basic design rules	53
6.2	Single family house	54
6.3	Apartment house.....	54

7	Conclusions.....	55
7.1	Contribution to overall picture.....	55
7.2	Relation to the state-of-the-art and progress beyond it.....	55
8	References.....	56
9	Appendices.....	58
9.1	Windows area ratio.....	58
9.1.1	Jyväskylä.....	58
9.1.2	Oulu	60
9.1.3	Stockholm	62
9.1.4	Oslo	64
9.1.5	Tromsø.....	66
9.1.6	Tallinn	68
9.1.7	Vilnius	70
9.1.8	Riga	72
9.1.9	Warsaw	74
9.1.10	Copenhagen.....	76

1 EXECUTIVE SUMMARY

IEE NorthPass-project aims at overcoming barriers on the very low-energy house markets in cold climate, such as the lack of well-defined concepts adapted to the severe climate conditions, awareness of very low-energy houses, lack of products on the market and customer attitudes.

In this report the NorthPass project consortium has collected and written down the main principles of designing a very low energy house and identified the special challenges to be met in the Northern European countries. The focus is especially on the challenge of the cold climate: colder air temperature, less sun light during the winter etc. when compared to most of the Middle European conditions. The national regulations or existing criteria were not taken into account, hence the analysis was purely based on physics and existing technical solutions.

The principles of the very low energy design can be summarized to:

1. *Minimise losses and consumption,*
2. *Maximize gains and*
3. *Substitute the remaining energy need with renewable and environmental friendly energies.*

These principles are illustrated with some typical examples and existing solutions.

The nature of the Northern European climate is illustrated with selected graphs. Also the influence of some significant factors is presented, e.g. the influence of the window orientation and quality to the space heat demand.

Finally, a parameter analysis for 10 different, representative North European locations – Jyväskylä, Oulu, Stockholm, Oslo, Tromsø, Tallinn, Vilnius, Riga, Warsaw and Copenhagen – was performed in order to determine input to a simple set of design rules and some comparable energy use levels to be applied when planning a very low energy residential building in the Northern Europe. Together with the general design rules for very low energy houses – e.g. the importance of the compact design and minimising thermal bridges – , these simple design rules – or performance requirements – can be summarized to a few points:

- Opaque constructions: U-values down to 0,06 – 0,12 W/m²K, depending on the climate
- Windows: Even in the coldest and darkest climates investigated, an orientation of the windows to the South is preferable. The thermal quality of the window is decisive: Very low U-values are preferred. External shading should be used to prevent extreme summer situations, and to consider daylight and view in the window design
- Ventilation heat recovery: It is important to have the best possible heat recovery, > 80-85%. To avoid freezing of the heat exchanger it is recommended in all Northern European climates to use a ground-coupled heat exchanger (direct or indirect).

These design rules are partly based on energy calculations performed within this project and partly results from previous studies. The energy demand levels are in the next deliverable D4 “Energy-demand levels and corresponding residential concept houses and the specific challenges of very low-energy houses in colder climates” used for definition of the concept houses.

2 INTRODUCTION

This is a report on principles of low-energy houses applicable in North European countries and their applicability throughout the EU. The objective of this report is to analyse the technical challenges of very low-energy houses in colder climates (e.g. the impact of very low heating demand level, freezing in heat exchangers and ground). Also information on the existing experiences with very low-energy houses and user/market demands have been collected. Two different energy demand levels for very low-energy houses in different North European countries have been defined: one level close to the current standards and another level adapted to the regional economic and climate conditions.

The report summarizes the main principles of designing a very low energy house and identifies the special challenges to be met in the Northern European countries. The focus is especially on the challenge of the cold climate: colder air temperature, less sun light during the winter etc. when compared to most of the Middle European conditions. These principles are illustrated with some typical examples and existing solutions.

The nature of the Northern European climate is illustrated with selected graphs. Also the influence of some significant factors is presented, e.g. the influence of the window orientation and quality to the space heat demand. Finally, a parameter analysis is performed in order to find some comparable energy use levels in 10 different, representative North European locations for very low energy houses. These are partly based on energy calculations performed within this project and partly results from previous studies.

3 THE PRINCIPLES OF A VERY LOW ENERGY HOUSE – IN GENERAL IN CLIMATES DOMINATED BY HEATING DEMAND

Minimise losses and consumption,

Maximize gains and

Substitute the remaining energy need with renewable and environmental friendly energies.

These are the basic rules to design buildings with very low energy consumption. There are several possibilities to reach the low energy consumption: using the combination of all three parts – minimise losses, maximize gains and substitute energies – or optimising mainly one of these. However, in the Northern Europe – and of ever increasing importance when the location is on a higher latitude – all these three factors must be optimised in order to reach the design that is equal with the low energy consumption: The final building design is a sum of many different factors, depending on the strategy that has been chosen.

This technical base goes along with the economical opportunities of the builder and should end in a very high comfort for the user and a long-term maintenance of value of the building for the owner.

To know the possibilities for building a very low energy house it is important to know the energy flux around the system house (Figure 1 and Figure 2).

The space heat demand for the heat supply is a *sum* of the transmission and ventilation losses *minus* the internal and external gains *multiplied* with the utilisation ratio (how much of the gains can be used) – see Figure 1. To the heat demand can add the domestic hot water demand. The house has electrical demand for the household appliances, lighting, auxiliary devices and of course for the fan. The total primary energy use of the building includes also the transportation and transformation losses for the delivered energy and is calculated with using some weighting factors (see Figure 2).

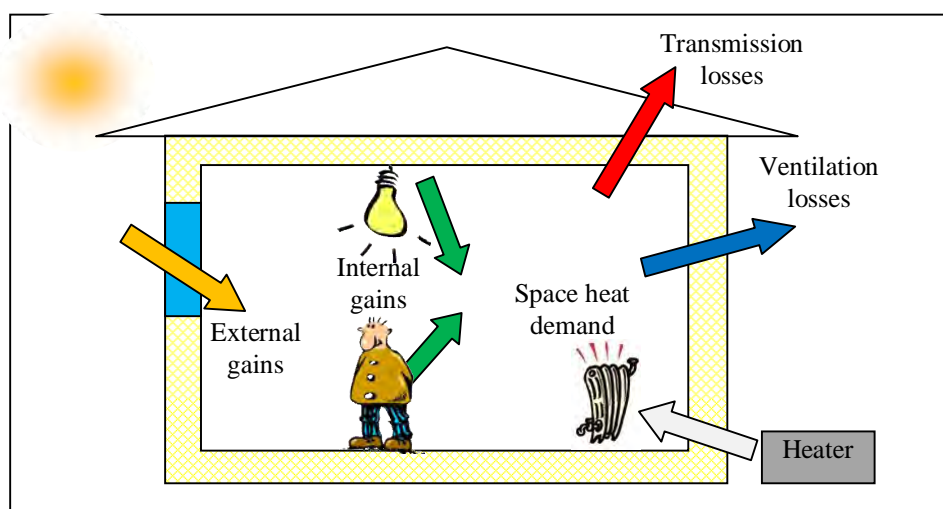

Figure 1. Space heat demand as result of the energy flux in the building

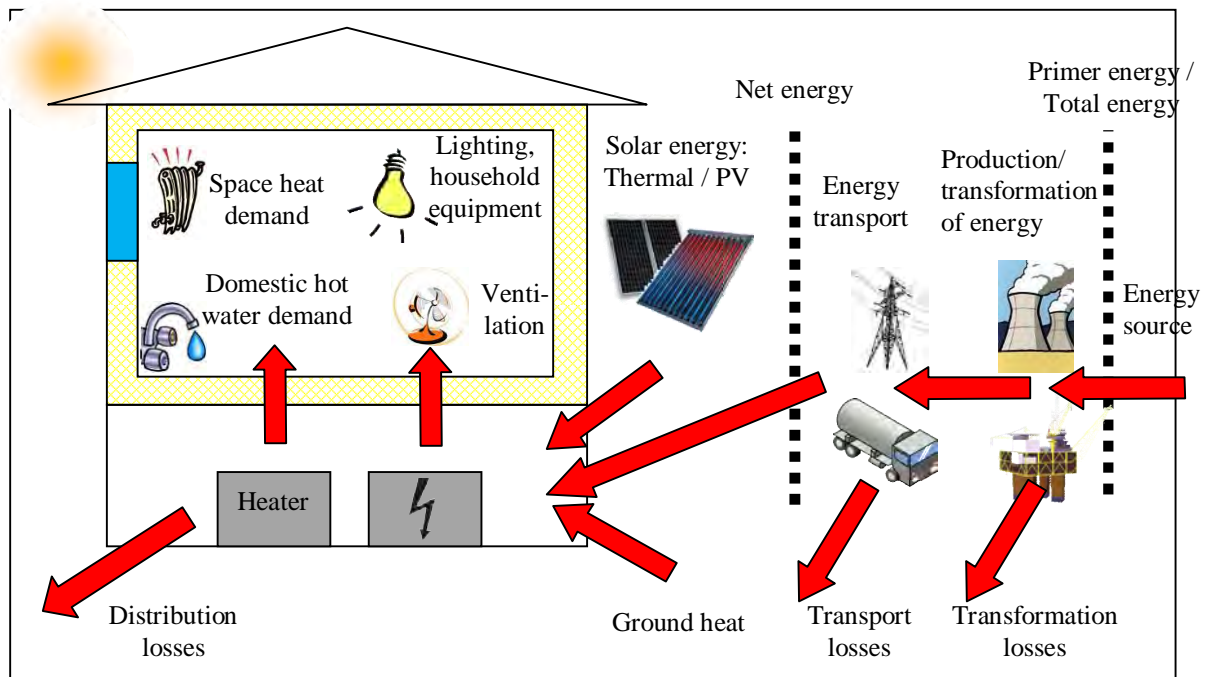

Figure 2. Energy flux for a building(-system)

The principles of a very low energy house can therefore be defined quite simple: One has to try to reduce the heat losses and to cover as much as possible of the remaining losses by the heat gains. All this is realized by optimising the building envelope and/or the building services (see Figure 3).

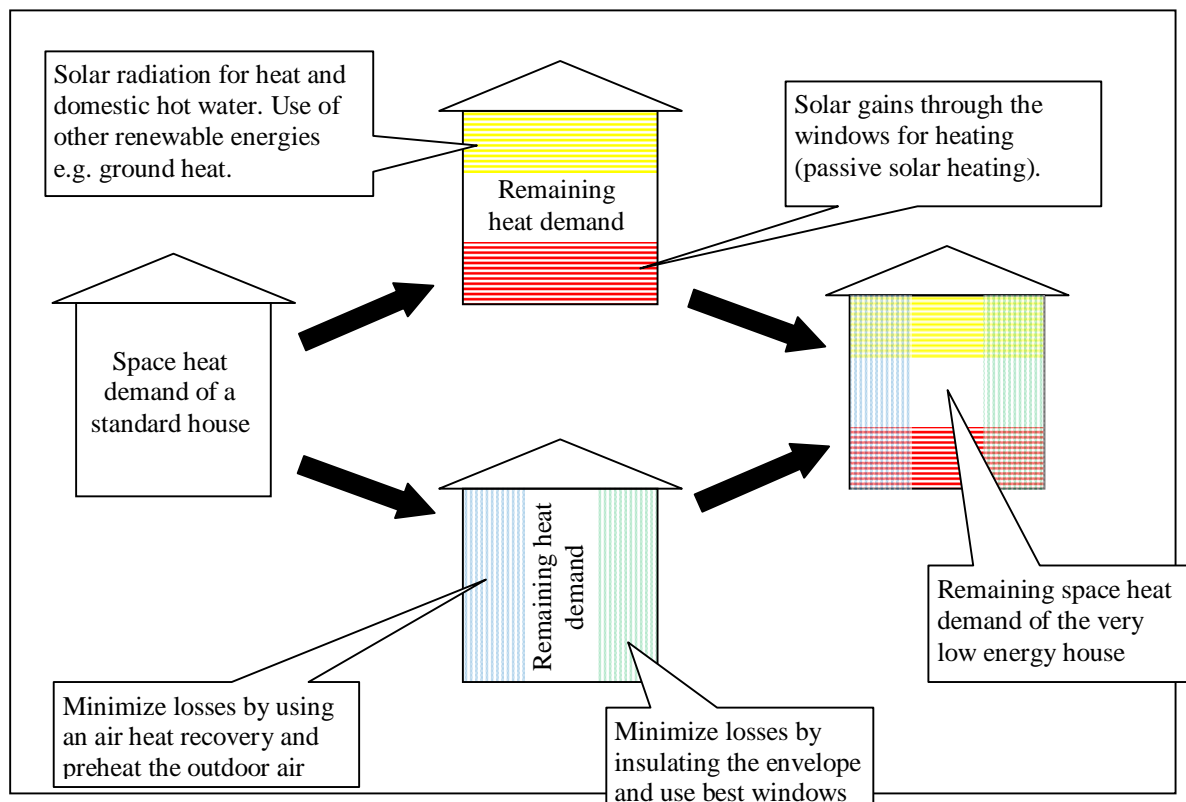

Figure 3. Interaction of building service and envelope with minimize losses and optimizing gains. (Figure based on a paper of Jenni Energietechnik, Switzerland)

An example on this interaction: The building with a well insulated thermal envelope and with a low supply temperature heating system based on a heat pump will result a better annual coefficient of performance – which again means lower energy use.

The following chapters show the state of the art and some views into the future of these important foundations of the very low energy building. It is important to understand, that not just by following one of these will succeed in a very low energy house. It is important to see the building as a system to be optimised, not just a sum of components. Therefore, all these aspects must be considered in the very early phase of the design.

3.1 Minimize losses by the building envelope

The central design rules of minimizing losses of a low energy house regarding the building envelope are, see also Figure 4:

- low U-values of both opaque constructions and windows
- minimal thermal bridges
- good air tightness of the envelope
- low ratio of thermal envelope to building volume (A/V)

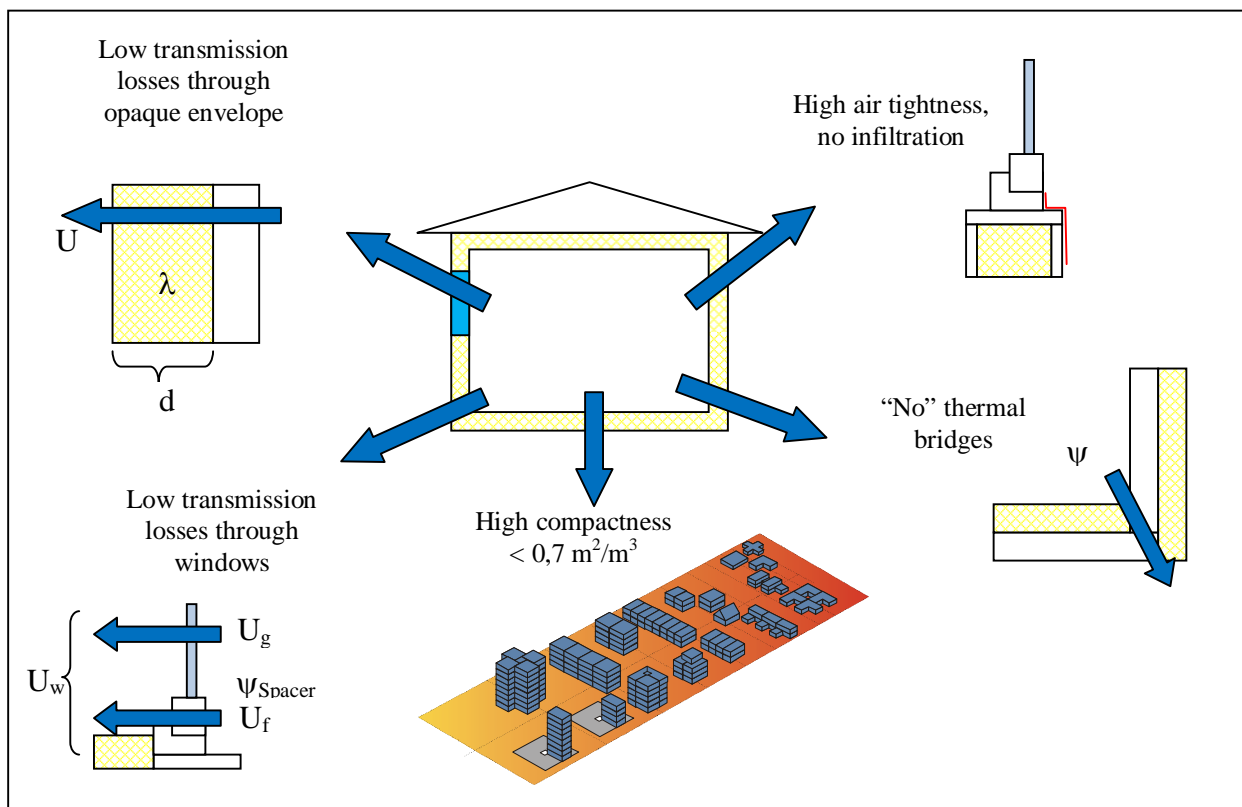

Figure 4. Important rules for minimizing heat losses

3.1.1 Building form and compactness

The compactness of a building body is one of the main features for a very low energy building. The compactness is given either as

- A ratio of the thermal envelope area to building volume, A/V [m^2/m^3] or as
- A ratio of the thermal envelope area to the floor area, A/A [m^2/m^2].

The more compact the building, the less is the area of the thermal envelope that causes the transmission heat losses. Moreover, a compact building has in general less thermal bridges.

Due to the fact that the energy key figures e.g. the space heat demand are usually declared as specific values (=divided by the floor area), a small A/V ratio or A/A ratio results in lower energy use figures. In other words, in a compact building, less envelope is divided by more floor area in comparison with a not compact building.

A schematic illustration of the resulting A/V relations for different building designs is given in Figure 5. As a rule of thumb for one- or two-family houses, $A/V < 0,7 \text{ m}^2/\text{m}^3$ when very low transmission energy losses are a goal. For large buildings A/V becomes almost automatically smaller, see Figure.

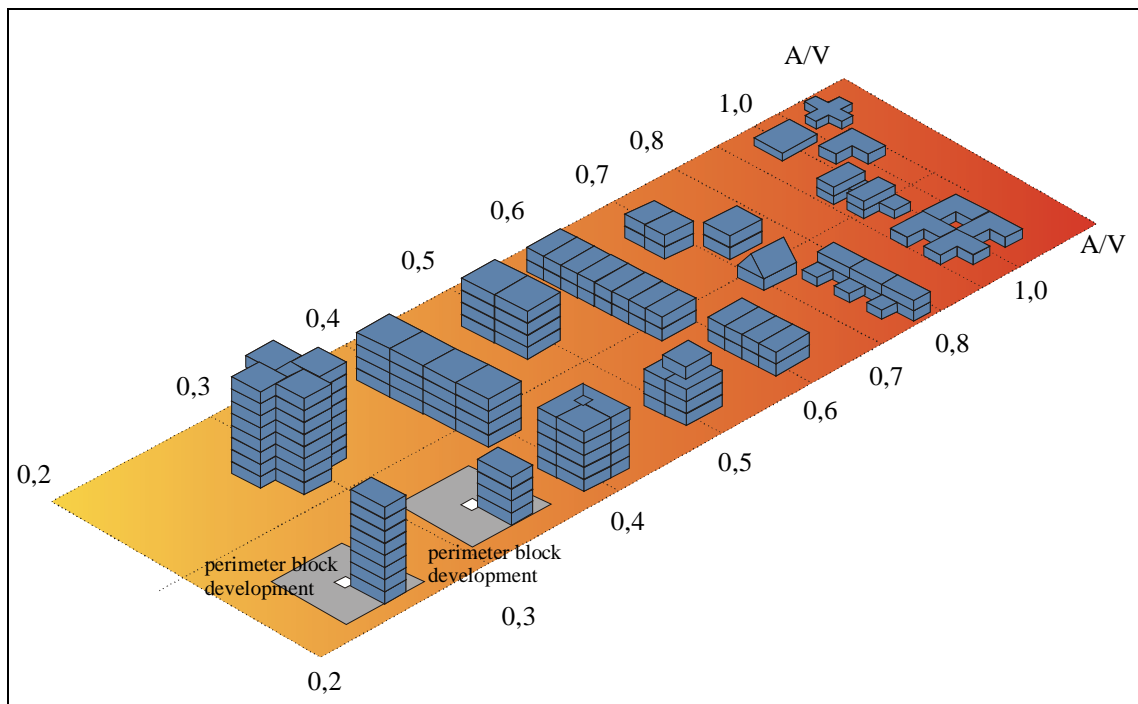

Figure 5. Scheme of different building types and their A/V ratio

Source: Passive House Institute, Darmstadt

A high A/V ratio has to be compensated with more insulation at the envelope – or other improvements e.g. better windows and higher heat recovery efficiency. An example on the influence of non-compact design on the resulting insulation thickness is given in Figure 6.

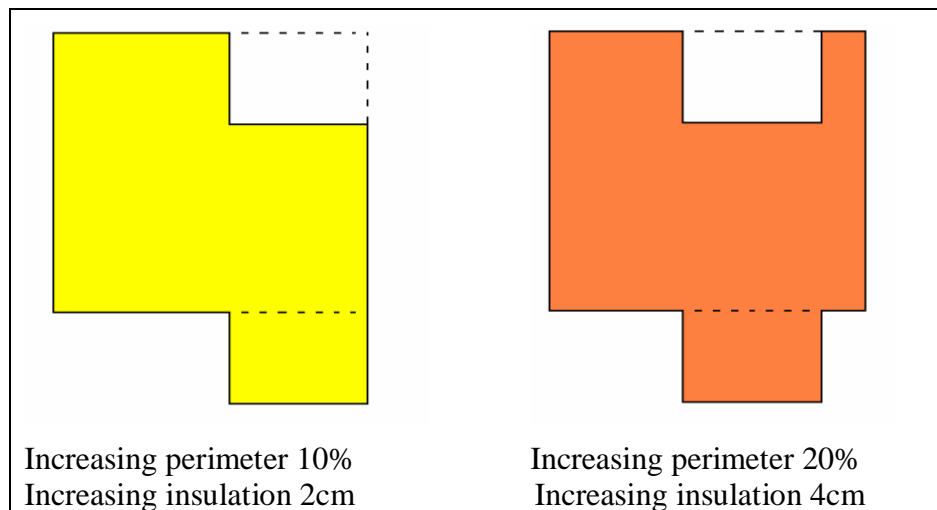

Figure 6. Influence of shape on perimeter and resulting insulation thickness

Source: CEPH Course material (R. Bosch-Laaks), Passive House Institute, Darmstadt

3.1.2 Opaque building envelope and thermal bridges

The thermal losses through the opaque building envelope Q [W] are the sum of all envelope areas A [m²] multiplied by each heat transfer coefficient, U-value [W/m²K] and the temperature difference between indoor air θ_i [°C] and ambient air θ_e [°C].

$$Q = \sum (U \cdot A \cdot f_T \cdot (\theta_i - \theta_e)) \quad (1)$$

Temperature factor f_T [-] is usually 1, but expresses the reduced effect of the temperature difference e.g. for constructions against ground and unheated rooms. U-value is given by equation 2:

$$U = \frac{1}{\sum R} = \frac{1}{R_{se} + \frac{d_1}{\lambda_1} + \frac{d_2}{\lambda_2} + \frac{d_3}{\lambda_3} + R_{si}} \quad (2)$$

where R_{se} and R_{si} [m²K/W] are the thermal resistances of the surface of the construction and d_1, d_2, d_3 , etc [m] the thicknesses of the material layers in the construction. $\lambda_1, \lambda_2, \lambda_3$, [W/mK] etc. are the respective thermal conductivities of these layers.

If the area of the thermal envelope is kept fixed, the U-value is the only parameter to be optimised – this means: to be reduced in order to minimise the heat losses. That can happen by

- increasing the insulation thickness, e.g. d_2 , or
- by using insulating material with a lower thermal conductivity e.g. λ_2

Doubling the thickness roughly halves the heat loss. By reducing the thermal conductivity to the half, halves the heat loss roughly, too. See an overview of the typical thermal conductivities of different insulation materials in Figure 7 and the illustration of the relation between thermal conductivity and needed insulation thickness in order to achieve certain U-values in Figure 8.

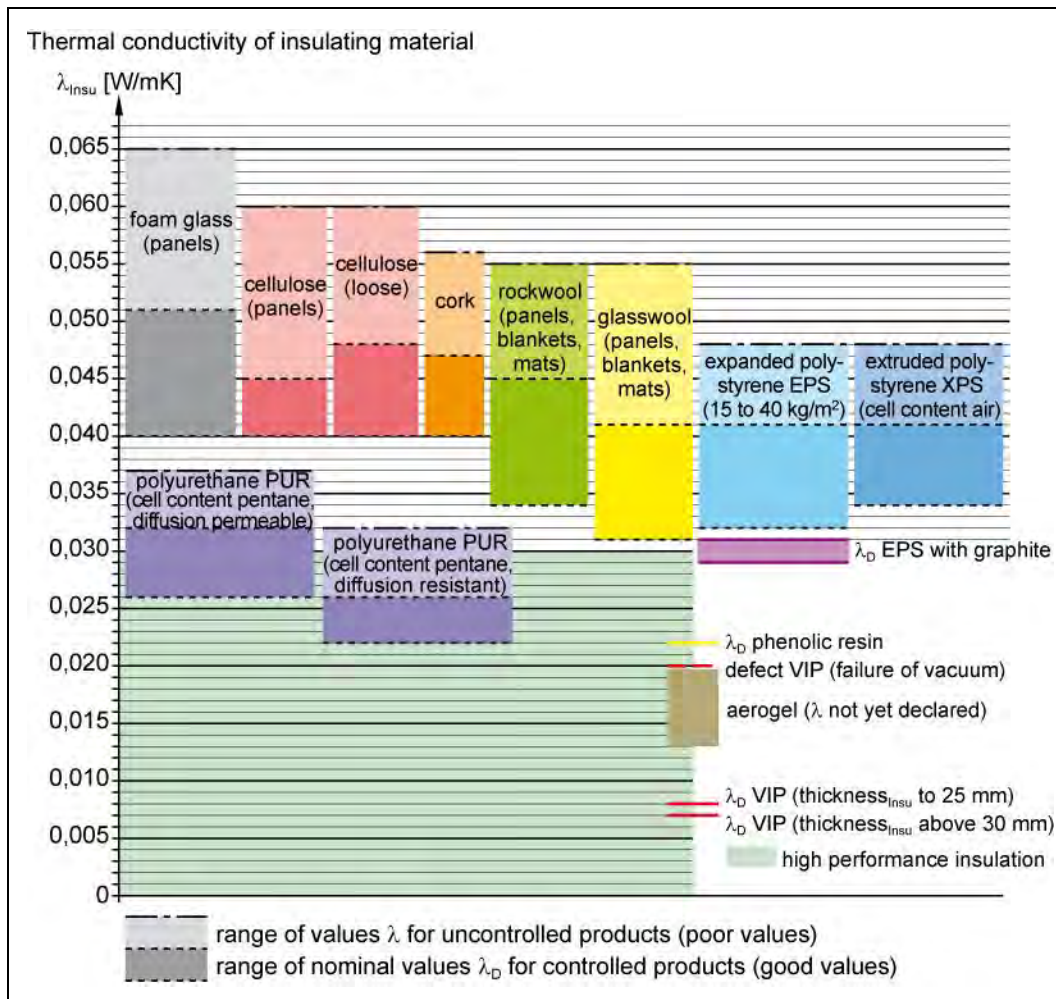

Figure 7. Thermal transmissions of various insulating material. VIP=Vacuum Insulation Panels. Source in German: Marco Ragonesi, Ragonesi Strobel & Partner AG Luzern, Switzerland

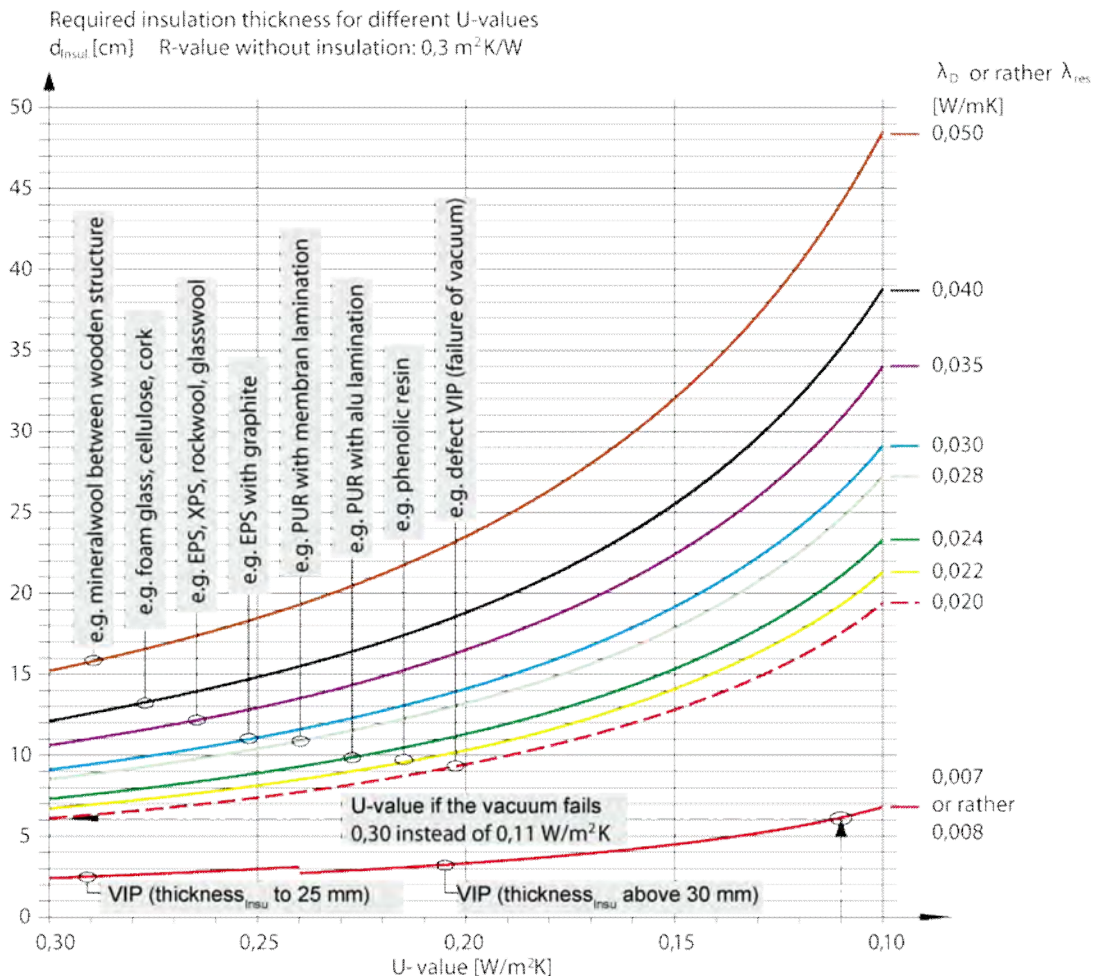

Figure 8. The thermal conductivity of the insulating material or rather of the resulting thermal conductivity of an inhomogeneous construction (e.g. wood/insulation) has a huge impact on the resulting thickness of the construction to reach a certain U-value. E.g. for a U-value of $0,1 \text{ W/m}^2\text{K}$ the construction thickness varies from 7cm with Vacuum Insulation Panels to 48cm with a mineral wool insulation in a traditional wooden construction. Source in German: Marco Ragonesi, Ragonesi Strobel & Partner AG Luzern, Switzerland

In addition to the minimising heat losses, low U-values of the thermal envelope result in higher temperatures of the internal surfaces. This means partly better thermal comfort - no radiant asymmetry – and partly lower/no risk of condensation or mould growth on the internal surfaces.

Traditionally, the building regulations have defined the maximum U-values. These U-values have practically set the standard for commercial constructions. When regulations are updated, the U-values get typically lower. Now, when the building regulations and all the different low energy concepts focus on the total (space) energy demand, the opaque constructions have very large range of U-values in the low range. The limiting factors for the very low U-values are often the total thickness of the wall and the price of the construction. Nevertheless, Scandinavian resellers of insulation material already have several standard constructions with U-values from 0.12 to 0.08 W/m^2 , see Figure 9 and Figure 10.

Depending on the insulation and other materials used, the total construction thicknesses of these well insulated constructions may typically vary from 350 mm for light weight walls up to 700 mm for attics insulated with loose fill insulation.

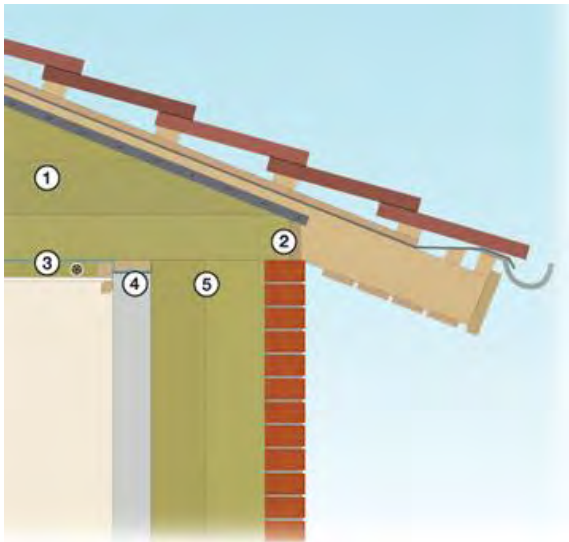

Figure 9. Roof/wall detail: 1. Insulation (2x145 + 120mm); 2. Wind barrier; 3. Insulation (45mm); 4. Airtight sealing; 5. Insulation (2x150mm)
 $U\text{-value roof} = 0.08$
 $U\text{-value wall} = 0.10$
 (Source: Rockwool.dk)¹

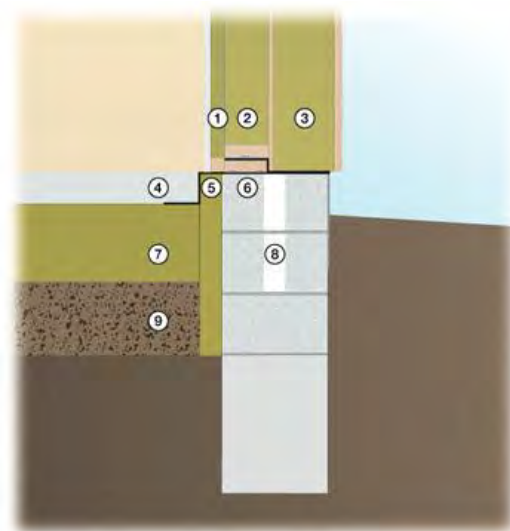

Figure 10. Wall/floor slab detail: 1. Insulation (45mm); 2. Insulation (100mm); 3. Insulation system; 4. Concrete; 5. Insulation (75mm); 6. Leca® Therm blocks (350mm); 7. Insulation (260mm); 8. EPS (70mm); 9. Light weight aggregate (260mm).
 $U\text{-value wall} = 0.09$
 $U\text{-value floor slab} = 0.09$
 (Source: Rockwool.dk)

In order to achieve as low U-values as possible with as thin constructions as possible - if keeping the constructions thickness small is important - the thermal bridges must be minimized in all parts of the building envelope. Thermal bridges are typically found there, where different parts of building envelope meet end in the corners of a building, see Figure 11. In addition, some structural construction types, e.g. wooden bearing beams, form systematic thermal bridges that also have to be minimized.

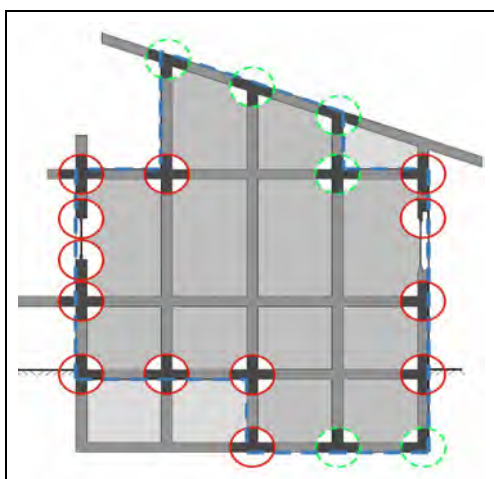

Figure 11. Typical locations of thermal bridges
 Source in German: Checkliste Wärmebrücken, EnFK, Switzerland

¹ <http://www.rockwool.dk/r%C3%A5d+og+vejledning/lavenergiuden/konstruktioner>

Another reason to reduce the thermal bridges is to avoid too low local temperatures of the internal surface of the thermal envelope. Local cold surfaces can mean increased risk for mould growth or even condensation and following decreasing indoor air quality.

The thermal bridge effect can therefore be expressed as a form factor $f_{R_{si}}$ [-] given in Equation 3. This factor is the ratio of the temperature difference between indoor surface θ_{si} and outdoor air θ_e to the total temperature difference between indoor θ_i and outdoor air θ_e .

$$f_{R_{si}} = \frac{\theta_{si} - \theta_e}{\theta_i - \theta_e} = 1 - U \cdot R_{si} \quad (3)$$

In case when there exists a pronounced thermal bridge, the indoor surface temperature is low and therefore the ratio small. Therefore, the higher $f_{R_{si}}$, the smaller is the thermal bridge effect. $f_{R_{si}} > 0,7$ is typically used as a design value in order to ensure no risk for mould growth: The relative humidity of the surface will in these cases only be too high if the indoor relative humidity is very high, too. Also homogenous constructions can be evaluated with respect to the average minimum surface temperature with the latter part of Equation 3, but it is not relevant for normal U-values as $f_{R_{si}} \gg 0,7$ for them.

The design of the building must be optimized already in the first stage to avoid thermal bridges. Following examples show some possible designs and quantify the possible savings by avoiding the thermal bridges.

An example on a construction with a huge thermal bridge is shown in Figure 12. The curtain-wall facing (U-value $0,10 \text{ W/m}^2\text{K}$) is fixed with the use of 2 fixtures per 2 m^2 with an iron T-square (with a point thermal bridge loss coefficient $\chi = 0,05 \text{ W/K}$). This thermal bridge doubles the resulting U-value of the whole wall and the losses, too. Another example (see Figure 13) is the bearing of a suspended ceiling. A linear thermal bridge loss coefficient ψ of $0,52 \text{ W/mK}$ for the “bad” solution increases the effective U-value of the exterior wall of $0,12 \text{ W/m}^2\text{K}$ by no less than 3 times, when the thermal bridge effect is added to the wall U-value. Of course there are much better solutions, see the improved solution in Figure 8.

Some more examples on thermal bridges and avoiding them are given in Table 3.

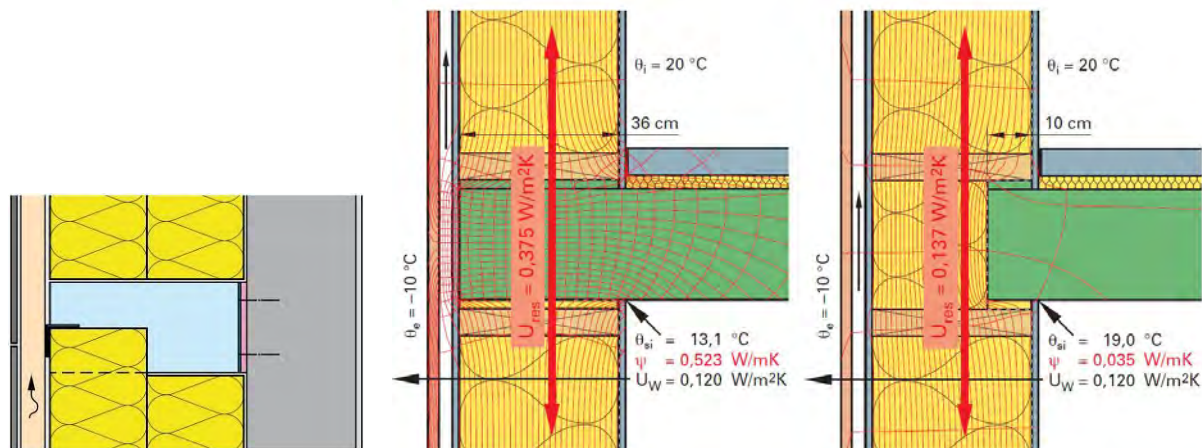
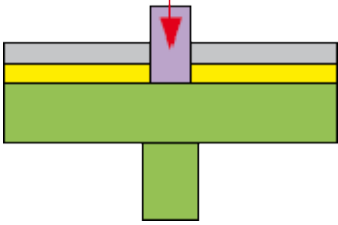
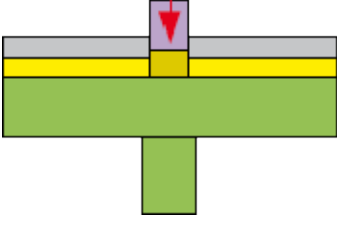
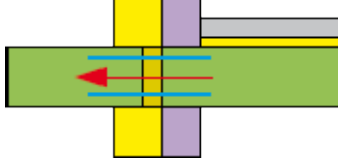
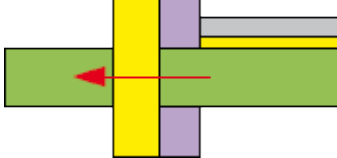
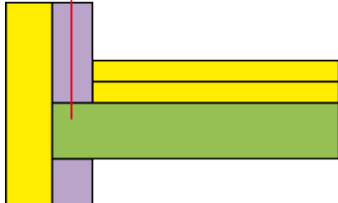
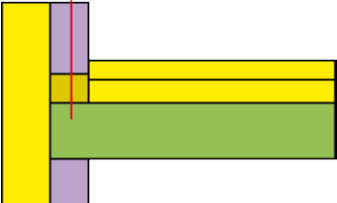

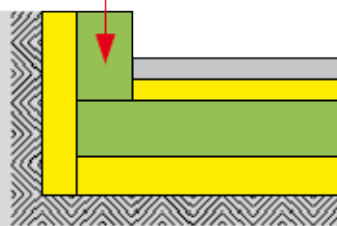

Figure 12. Fixture of curtain-wall facing
Source: Marco Ragonesi, Ragonesi Strobel & Partner AG Luzern, Switzerland

Figure 13. Bearing of a suspended ceiling
Source: Marco Ragonesi, Ragonesi Strobel & Partner AG Luzern, Switzerland

Table 3. Typical examples of poor and fine solved thermal bridges examples from [2].

Type	poor/normal detail	optimised detail
Interior wall made of lime sand brick	$\psi = 0,55 \text{ W/mK}$  without thermal separation	$\psi = 0,17 \text{ W/mK}$  with thermal separation
Balcony	$\psi = 0,30 \text{ W/mK}$  with thermal separation	$\psi = 0 \text{ W/mK}$  balcony on it's own construction
Attic rail	$\psi = 0,25 \text{ W/mK}$  without thermal separation	$\psi = 0,04 \text{ W/mK}$  with thermal separation
Roof edge	$\psi = 0,22 \text{ W/mK}$  without thermal separation	$\psi = 0,07 \text{ W/mK}$  with thermal separation
Fundament / floor slab		$\psi = 0,06 \text{ W/mK}$  thermally separated enclosure

3.1.3 Windows and the installation of them

A significant part of the transmission heat losses of any building are the losses through the windows. Even a relatively good window with a U -value of $1,0 \text{ W/m}^2\text{K}$ has the same heat loss as a 10 times larger opaque wall with a U -value of $0,1 \text{ W/m}^2\text{K}$. Nevertheless, the development of the window glasses, frames and spacers has been huge in the last years. There are available glass with $U_g = 0,4 \text{ W/m}^2\text{K}$ (see also 3.3.1), spacers with $\psi_g = 0,03 \text{ W/m}$ and frames with $U_f = 0,7 \text{ W/m}^2$.

In order to achieve such low U_g – values as $0,4 \text{ W/m}^2\text{K}$, a window glass panel with 3 layers with low emission coating and the gaps filled with krypton is required. This inert gas is very rare and therefore very expensive. An alternative is to use argon, which results in glass U -values around $U_g = 0,6 \text{ W/m}^2\text{K}$. This is still a good but a much cheaper glass.

To compensate the losses of the transparent part of the window, a very good frame is necessary. There are two main possibilities: To use a huge and very good – and expensive – frame, or a more conventional and smaller frame which is installed in the wall such a way that the wall insulation can cover the window frame as much as possible. Some examples on very good frames and installation of them are shown in Figure 14 to Figure 17 below.



Figure 14. ENERsign window
Source: Pazen Fenster + Technik GmbH; Zeltingen-Rachtig

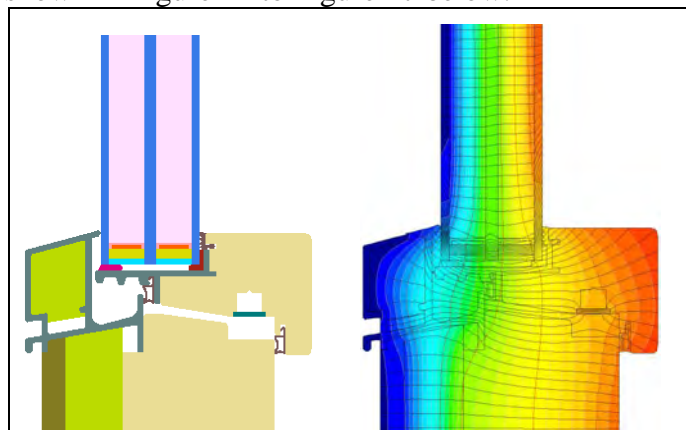

Figure 15. Cross section and isotherms and heat flux diagram of ENERsign window. $U_f = 0,69 \text{ W/m}^2\text{K}$

Source: Passive House Institute Darmstadt



Figure 16. Thermoline 110 window
Source: Bracia Bertrand Sp.J. ul., Luzino

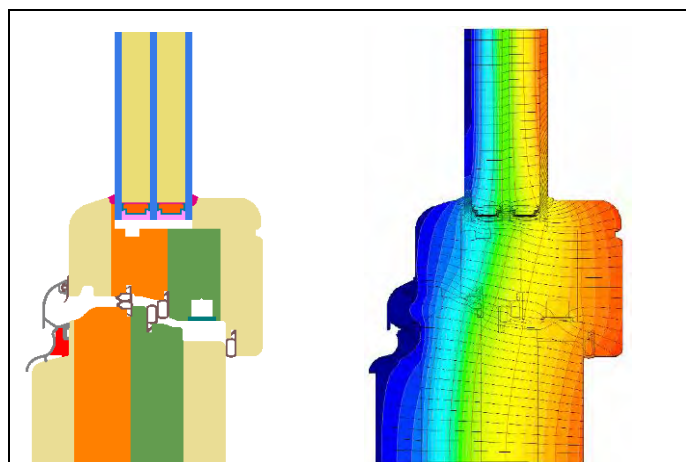

Figure 17. Cross section and isotherms and heat flux diagram of Thermoline 110 window. $U_f = 0,69 \text{ W/m}^2\text{K}$

Source: Passive House Institute Darmstadt

The most important parameter for energy efficient window frames is the U –value of the frame U_f . Good window frames have U-values down to under $U_f = 0,7 \text{ W/m}^2\text{K}$. For the energy balance of the building, however, another important parameter exists for the window frame: The width of the frame, b_f [m]. A wide frame reduces the transparent part of the window and increases the total heat losses as the U_f is normally several times higher than the U-value of the exterior wall.

Therefore, to be able to compare the frames with very different widths, it is important to use the same glass measure for all window frames to be compared as suggested in [3]. This leads to a very simple way of characterization of the frames with a specific heat loss h_f [W/mK]:

$$h_f = U_f \cdot b_f + \psi_g \quad (4)$$

where ψ_g [W/mK] is the linear heat transfer coefficient of the spacer. Some characteristics of some good window frames and glass spacers are given in Table 4. The installation of the window in the wall may cause a significant thermal bridge if there is not taken care of the design of this detail. This thermal bridge adds also to the heat loss of the building and must be taken into the calculations.

Table 4. Characteristic values for different window frame including the spacer from some companies represented in Scandinavia and Eastern Europe. Source: PHPP 1.6 database[4].

Company / Type	Frame U-value [W/m ² K]	Frame Width [m]	Spacer*) Linear heat loss coefficient [W/mK]	Frame Energy loss per meter frame [W/mK]
Bracia Bertrand - Thermoline 110 - with spacer 'TGI-Wave'	0.69	0.138	0.042	0.137
DOLETA - DOLETA PASSIV WINDOW - with spacer 'Thermix'	0.73	0.148	0.039	0.147
Inoutic - Inoutic Prestige Passivhaus - with spacer 'Swisspacer V'	0.79	0.127	0.030	0.130
Internorm - edition passiv - with spacer 'Thermix'	0.73	0.114	0.038	0.121
Internorm - edition passiv fix glassing - with spacer 'Thermix'	0.63	0.096	0.043	0.103
Internorm - edition 4 passiv composite window frame – with stainless steel spacer	0.96	0.114	0.039	0.148
Internorm - varion 4 passiv / vetro-design composite window frame – with stainless steel spacer	0.92	0.114	0.038	0.143
Internorm - varion 4 FF-Flügel composite window frame – with stainless steel spacer	0.92	0.114	0.038	0.143
Internorm - thermo3 passiv - with spacer 'Thermix'	0.71	0.123	0.038	0.125
PAZEN Fenster & Technik - ENERsign - with spacer 'Thermix'	0.68	0.100	0.033	0.100

*) These spacer values are the same as the ones used for the calculation of the U-value.

Air tightness of the thermal envelope

One of the “basic rules” of very low energy buildings is to minimise heat losses by controlling the heat losses due to air change. This means that the building is made as air tight as possible in order to minimize the uncontrolled in- and exfiltration, and the air change, based on the fresh air demand, is supplied by mechanical ventilation with heat recovery.

The air tightness of the building is usually given as an n_{50} -value, which corresponds to infiltration/exfiltration due to cracks and gaps in the building envelope when there is a 50 Pascal over- or under pressure. The influence of this grade of air tightness on the resulting heating load and heating demand of a building is illustrated in Figure 18. It also shows the widely used criterion for the air tightness $n_{50} < 0,6 \text{ h}^{-1}$ used e.g. by the passive house standard and many other low energy concepts.

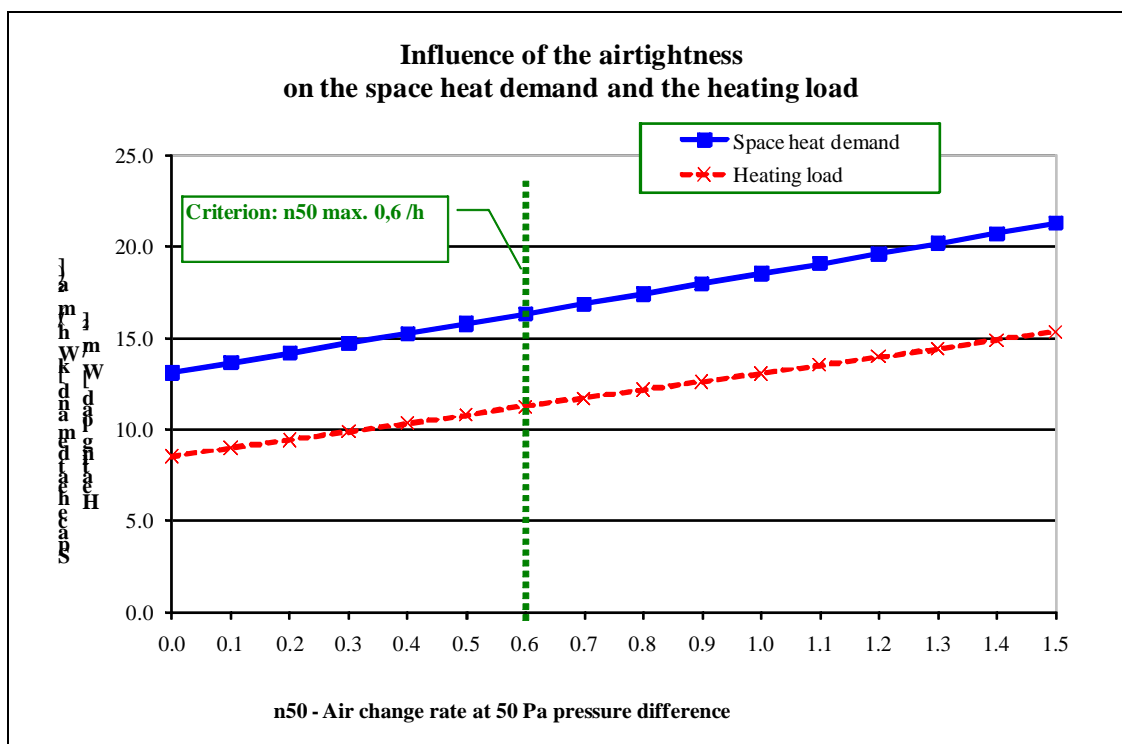

Figure 18. Influence of the air tightness (n_{50}) on the space heat demand and heating load
Source: CEPH Course, Passive House Institute, Darmstadt

Wind and buoyancy cause the air flows through gaps in the building envelope. An air flow from outside to inside (infiltration) leads the cold air in and causes increased heating demand and draft effects. Building physically it is regarded as non-critical as the building components stay dry. An air flow through constructions into inside, however, can also carry unwanted components of air e.g. mould spores and VOC's into room air.

The flow from inside to the outside is always critical in the cold climates, as warm and humid air can condense on the cold areas of building envelope and can lead to constructional damage. In addition, for a ventilation system to work properly, an airtight building envelope is indispensable.

Severe heat losses due to infiltration occur in poorly tightened buildings. Typical flaws are found in joints of different building components, e.g. around windows. Therefore, the air tightness has to be planned in detail for the whole building and explained to the craftsmen. Some examples on the details, where the air tight layer is given, are found in Figure 19 and Figure 20.

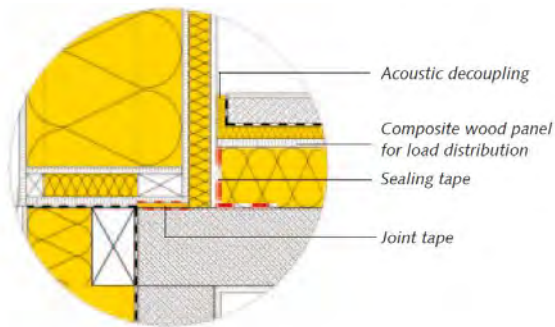

Figure 19. Connection outer wall (timber construction) to floor above unheated cellar. (Source: Isover.com)

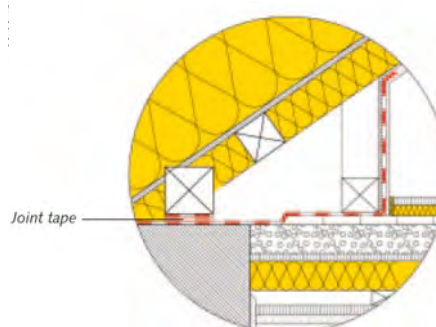

Figure 20. Connection detail airtight layer rafter roof and wooden joist ceiling with the jamb wall. (Source: Isover.com)

3.2 Minimize losses by the building system

3.2.1 Ventilation heat recovery

The ventilation heat losses depend on the building air volume V [m^3], ventilation air change rate n [h^{-1}], the heat capacity of the air $c_{p,\text{air}}$ [J/kgK] and the temperature difference between outdoor and indoor air, here given as heating degree hours G_t [Kh/a]:

$$Q_v = V \cdot n \cdot c_{p,\text{air}} \cdot G_t \quad (5)$$

The ventilation rate is usually given by the building regulations and should provide a good indoor air quality. Typically $n = 0,5 \text{ h}^{-1}$. As the reduction of the ventilation rate is not generally recommended, the only way to reduce the ventilation heat losses is to introduce the heat recovery of the ventilation. Because of the very low in/exfiltration rates of an air tight building, most the ventilation – and the losses, too – can be controlled.

The ventilation loss is therefore the heat, which is not recovered by the air handling unit. Figure 21 illustrates the magnitude of the heat recovery to the space heating demand of a building.

The effect of a good heat recovery is significant because the losses are the difference between the heat recovery effect and 100%. That means, that the losses are doubled by using a 80% heat recovery unit ($100\% - 80\% = 20\%$) than a 90% heat recovery unit ($100\% - 90\% = 10\%$).

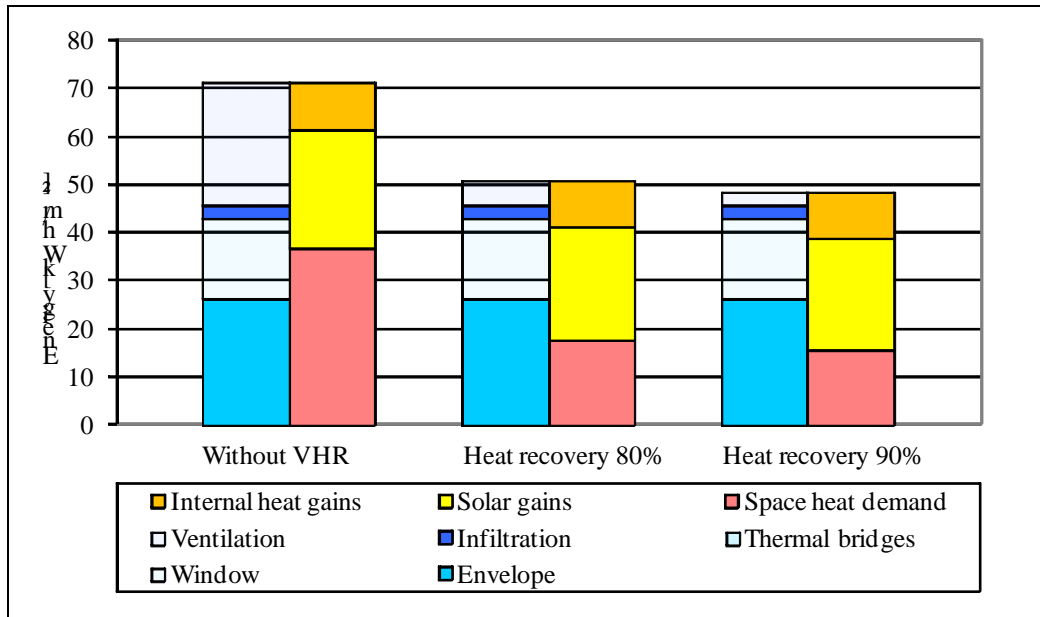

Figure 21. Energy balance (kWh/m^2) without heat recovery, with 80% and with 90% heat recovery calculated for a single family house.

There is a wide range of air handling units on the market and different qualities of the units. At least among the small units (100 to 400 m^3/h) as shown in Figure 22 there are a few products with a very good energetic quality: the high degree of recovery in the same time with low electricity consumption.

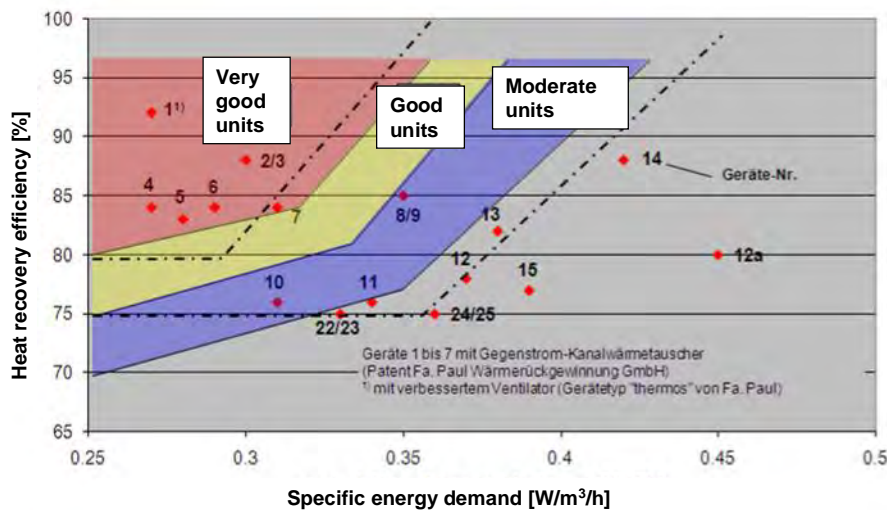

Figure 22. The heat recovery efficiency of different heat exchanger units as a function of power consumption [5].

Apartment houses would often have central, larger air handling units (600 to 3000 m^3/h). The heat recovery effect is normally around 70 to 80% for the larger units, which makes the ventilation heat losses twice as big compared to the small units. But there are solutions coming up with two heat exchangers behind each other or longer heat exchangers. Of course, it is also possible to use small, effective de-central units in apartment houses, too, but these may not be cost efficient.

3.2.2 Insulation of heat distribution

Beside the very good thermal insulation of the building's thermal envelope, the attention must also be paid on the reduction of the heat losses from the distribution of heat and domestic hot water. Studies have showed that the losses of the heat and domestic hot water distribution can be huge, e.g. [5].

When the heat losses are within the thermal envelope it gets back as internal heat gain, which is useful during the heating season. But most likely the heat is not there where it should be. Especially when heating with the air, the whole concept can fail, if the duct insulation is insufficient or not existing. An example on the effect of insulation thickness of the ducts and the length of them on the resulting air temperature and the delivered heating effect is given Figure 23.

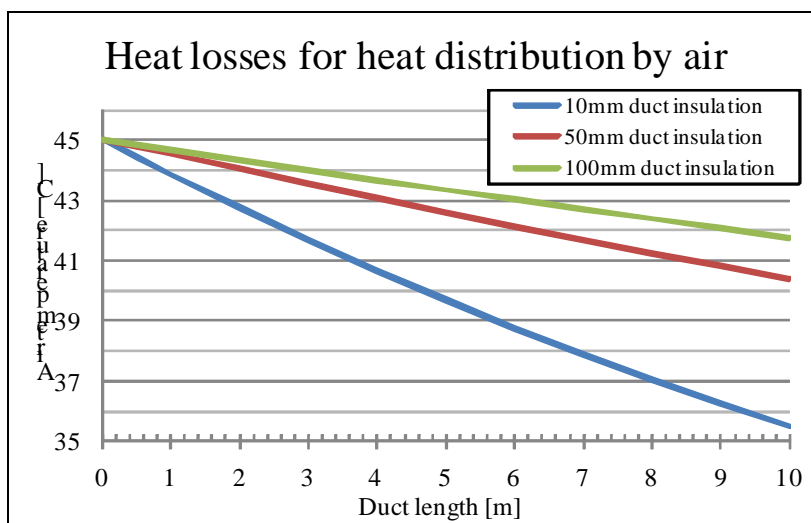

Figure 23. The resulting air temperature of a heat distribution by air as a function of different duct lengths and insulation thickness (duct \varnothing 100mm, length 10m, air volume $50 \text{ m}^3/\text{h}$, starting temperature 45°C). An example: For a room temperature at 20°C , the inlet temperature of 41°C will result in a heat effect on 336 W and the inlet temperature of 35°C will result in a heat effect on 240 W.

The losses from the domestic hot water distribution must be minimized as much as possible, too. Therefore, the basic principles of the efficient installations in a very low energy house are:

- use short distribution distances
- use well-insulated pipes, pumps and valves
- use low temperatures.

3.3 Maximizing gains by the building envelope

Utilization of the solar heat is the main way to gain free heat in a residential building. There are two dominating factors:

- orientation of the building/windows and
- the properties of the window glass.

Internal heat gains (heat from persons and electrical appliances) are not usually a subject for optimisation as the heat load from electrical appliances should be minimised in order to keep the total energy use of a building low, too. A common misunderstanding is that extreme low energy houses are heated by increasing the use of electrical appliances and letting them be switched-on. Therefore, only the ways to optimise solar gains are relevant and are discussed in this chapter.

The central design rules of optimising gains of a low energy house regarding the building envelope are:

- the optimal orientation of the windows
- as less fixed shading as necessary (but with an external flexible shading)
- the glass size and type according to the climate, place and orientation.

The optimal window orientation, size and glass type are a function of the actual building design, location and climate, and must therefore be found for every project.

3.3.1 Orientation of the building

For a very low energy building, the intensive use of gains of solar radiation is essential. The most effective way to utilize the solar gains is to optimise the building for the winter time and protect the building from too much solar gain through the summer by mechanical shading.

Figure 24 and Figure 25 illustrate the differences in solar gains and the resulting space heating demand for different window orientations. The building is optimised for solar gains from south, which means that most of the windows are on one façade.

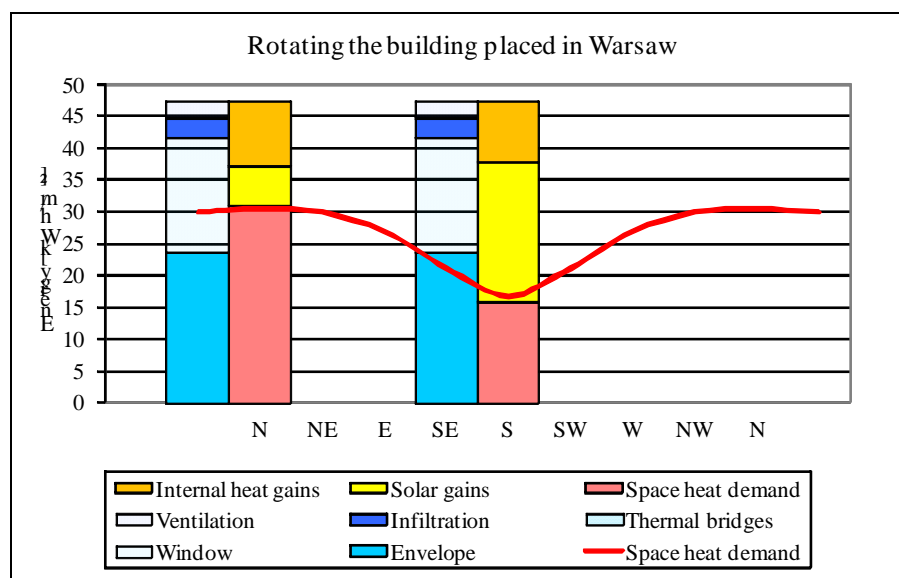

Figure 24. Energy balance of a very low energy house situated in Warsaw, calculated for every 45°. The red line is the resulting space heating demand.

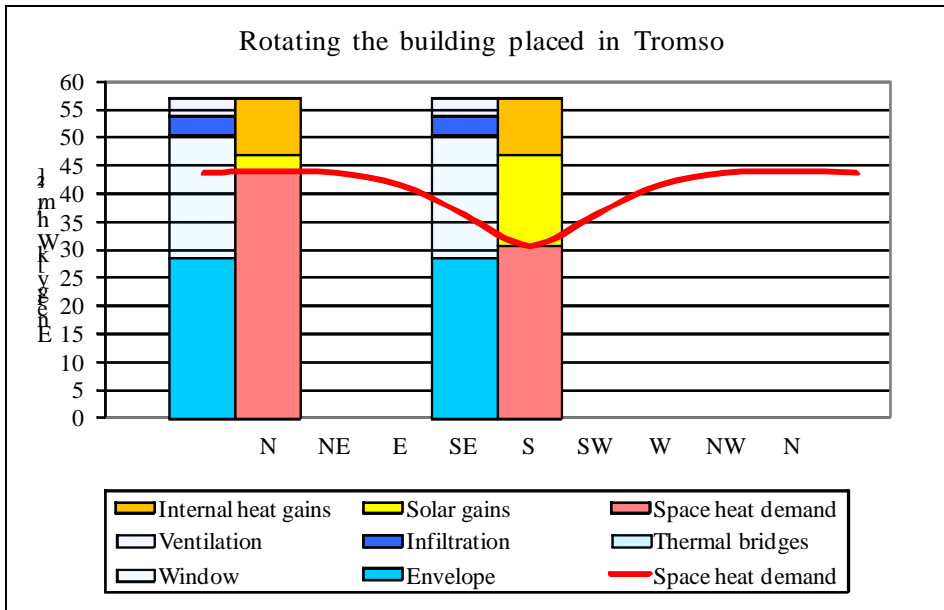

Figure 25. Energy balance of a very low energy house situated in Tromso, calculated for every 45°. The red line is the resulting space heating demand.

Depending on the actual location of the building, the horizontal shading can be significant or not existing, see Figure 26. The orientation of the building can be chosen by the builder, while the shading of the horizon – mountains, other buildings, etc. – is fixed. Therefore, if the shading is not taken into account from very beginning of the design process, the solar gains can be more or less lost.

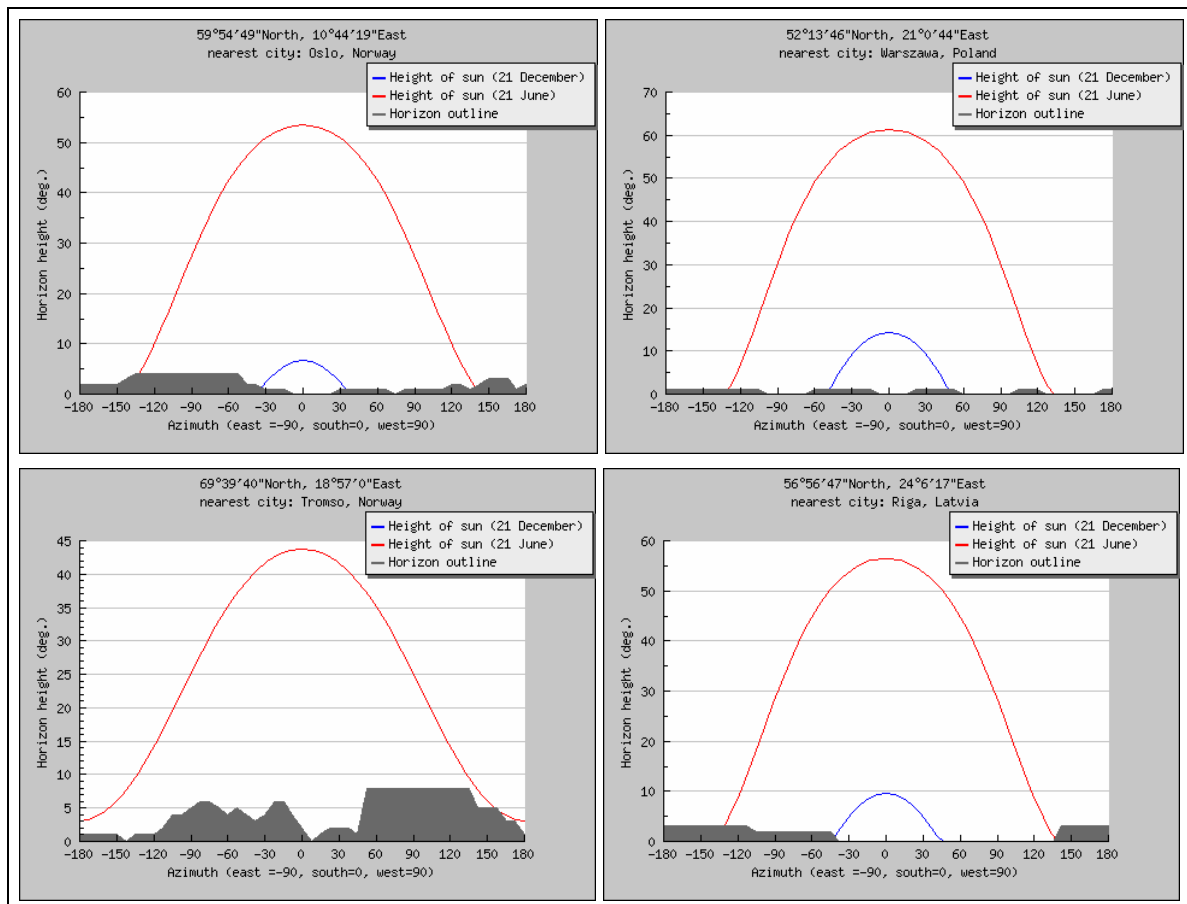

Figure 26. Horizontal shading and solar heights in summer and winter for Oslo, Warsaw, Tromsø and Riga. Diagram generated with <http://re.jrc.ec.europa.eu/pvgis/>

Another type of fixed shading is depending on the architectural design and the window details: the reveal type and depth and the overhang type and depth (see Figure 27). However, optimising of these is important and must be paid attention to.

When optimizing the winter situation, it is very important to design the summer situation, too. The effort of utilization as much of the solar radiation as possible during heating season typically results in overheating during warm and sunny days, if no effective solar shading is implemented. It is very important to use shadings for each window. The best and only solution for a high quality building is external shading. There is the possibility of interior positions of the shading, but that is normally not effective enough.

To reduce the temperature peaks during warm, sunny days, thermal mass of the building should be high enough. In this way, the solar excess energy can be accumulated through the day and emitted through the night. However, usually the thickness above 100 mm of the heavy constructions does not add to the effective thermal mass. When the solar gains are effectively controlled with proper window and shading design, the thermal mass is less important in a very low energy house.

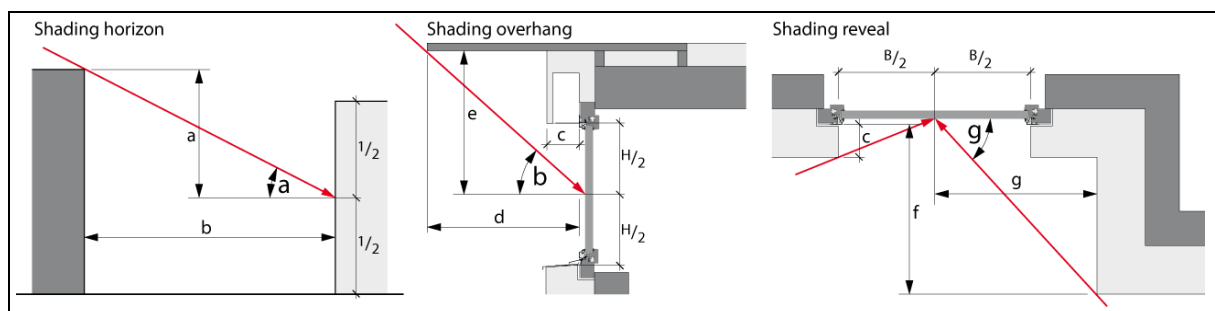

Figure 27. Illustration of the shading types for horizon, overhang and reveal. Source: Energy calculation tool Enerhaus 380/1

3.3.2 The optimal window glass

The windows and especially the window frames cause a significant part of a heat losses of the thermal envelope due to the relatively high U-values of windows compared to the opaque parts. On the other hand, the window glass enables the utilization of the passive solar gains. The window glass g-value (solar heat gain coefficient) [-] determines how much of the power of the solar radiation goes through the glass.

U- and g-values of the window glasses are controlled and tailored by number of glass panes, different gas fillings and low emissivity coatings. The role of panes and gas fillings is to reduce the heat losses by reducing the thermal conductivity through the glass system. The role of coatings is to allow the short wave solar radiation to enter the building and prevent the long wave radiation, heat, to get out again.

From the solar gain optimizing point of view, the g-value should be as high as possible. In the same time, the U-value should be as low as possible in order to minimize the heat losses. Figure 28 shows the g-values as a function of the U-value for more than 300 different window glasses. The window glass data from PHPP are found in that area where the combination of the g- and U-values is optimal: minimal heat loss and maximal solar gain. Therefore these window glasses are recommended to be used in passive houses and any other very low energy houses, where the goal is a low space heating demand by passive means.

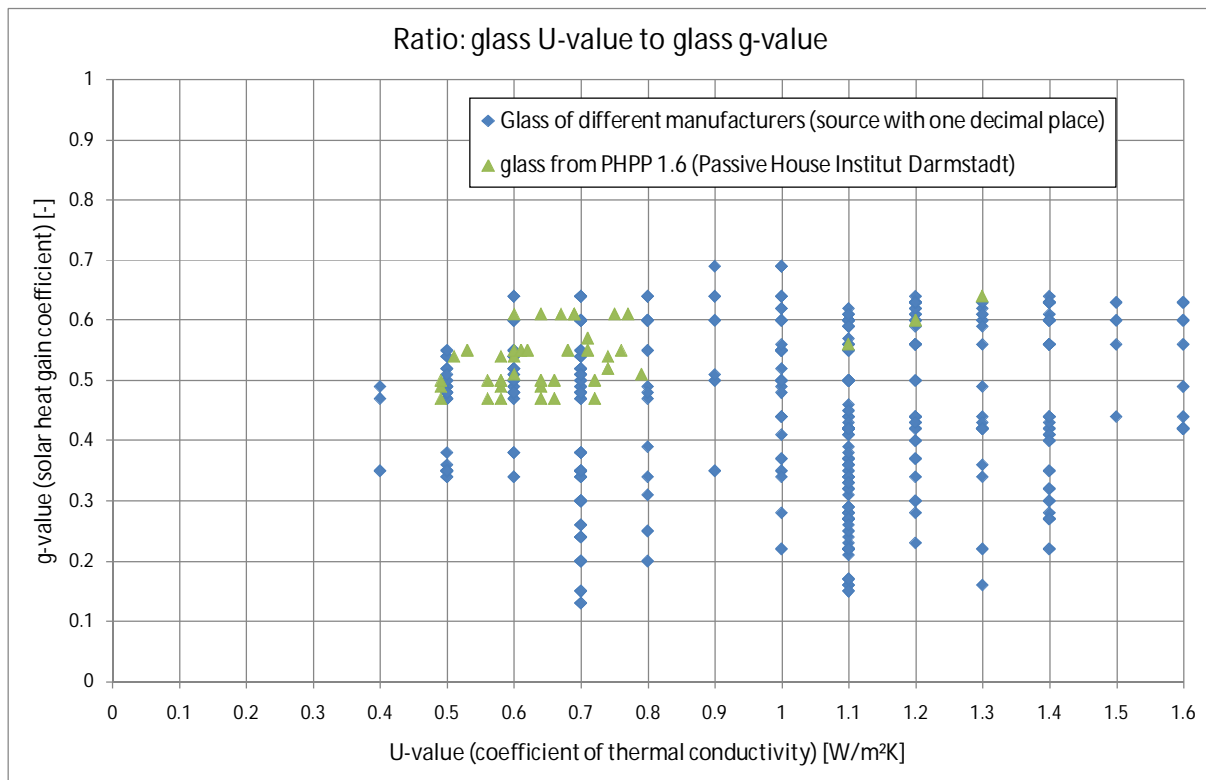

Figure 28. *g-value (according to EN410) and U-value (according to EN673) comparison of window glass. Data from manufacturers and the PHPP database.*

In the future product development, the focus will be e.g. on a glass with a high level of transparency with a low U-value.

3.4 Maximizing/using environmental gains by the building system

Besides minimizing the energy demand, supplying the rest energy needs in an efficient and environmentally friendly way, are the main principles of a very low energy building. An efficient and intelligent control of the building systems is an essential part of these principles: No heat and no electricity should be used unmotivated!

3.4.1 Building control system

A simple building control system is to use single room temperature controllers for the heat supply such as floor heating or radiators. That can control heat supply by considering the gains entering each room. It is possible to use a flow controlled temperature control on the heat plant that gives warmer flow by lower outside temperatures.

There are of course more advanced management systems e.g. KNX²-devices on the market. They cross-link all control and the energy supply functions. The advantage is that all building techniques, home appliance and light are connected. In present time, these kinds of systems are still expensive, but innovative and flexible.

² KNX is a standardised network communications protocol for intelligent buildings. KNX is the successor to, and convergence of, three previous standards: EHS, BatiBUS and EIB. The KNX standard is administered by the KNX Association. KNX separates the control functions and the energy supply from each other. All devices are connected to a bus with each other and can share data. The function of each bus is defined by their programming, which can be readily modified and adapted.

3.4.2 Thermal solar panels and photovoltaics

The energy losses of a building should be covered using as much renewable and environmental friendly energy as possible. By making use of e.g. solar earnings there is a possibility to a fully or partly substitution of conventional energy sources which have to be paid and carried on from distance. It is of course necessary to have enough sun on the building.

There are two established ways to utilize active solar energy on site to produce:

- thermal energy by solar panels (Figure 29) and
- electricity by photovoltaics (PVs) (Figure 30).

The solar panels can have energy efficiencies around 50% but the annual production depends on the heat losses and thus the exterior temperature, and if there is a need for hot water at the same time as there is production.

Photovoltaics producing electricity can have energy efficiencies around 5-18%³. The system itself has a smaller efficiency because of transport and transformation losses.

To give a precise statement on the resulting degree of coverage is not possible and a good knowledge about energy demand and the building installation is needed. However, calculations with the PHPP for Copenhagen shows that 10 m² solar panels can cover up to 70% of the domestic hot water demand in a single family house (in southern Scandinavia) and 4-5 m² solar panels can cover up to 50%.

A photovoltaic system with 10 m² and 1 kWp load and system losses from around 20% can produce in Oslo around 7800 kWh/year by a specific system of 1kWp/10m² (Calculation with: <http://re.jrc.ec.europa.eu/pvgis/>).

Actually there also exist products on the market already now that combine these two energy producing technologies in one system as a hybrid solar panel.



Figure 29. Picture of solar panels.
Source:



Figure 30. Picture of PV plant on a building.
Source:

³<http://www.thema-energie.de/energie-erzeugen/erneuerbare-energien/solarwaerme/auslegung-montage/wirkungsgrad-von-solaranlagen.html>

3.4.3 Heat from ground / Geothermal energy (anergy)

In many cases it is possible to gain some energy for free by using a ground source heat pump. The source can also be ground water or waste heat or anergy in a distribution network (see Figure 32). The advantage of all these sources is the quite high temperature level on the primary side (on the contrary to an air heat pump). This results in a better annual coefficient of performance (COP), see Figure 31 for measured COP according to EN 255. The resulting COP depends on the actual temperatures in the system on the site. If the temperatures are lower than according to the test conditions, the average COP will be lower than in Fig. 31.

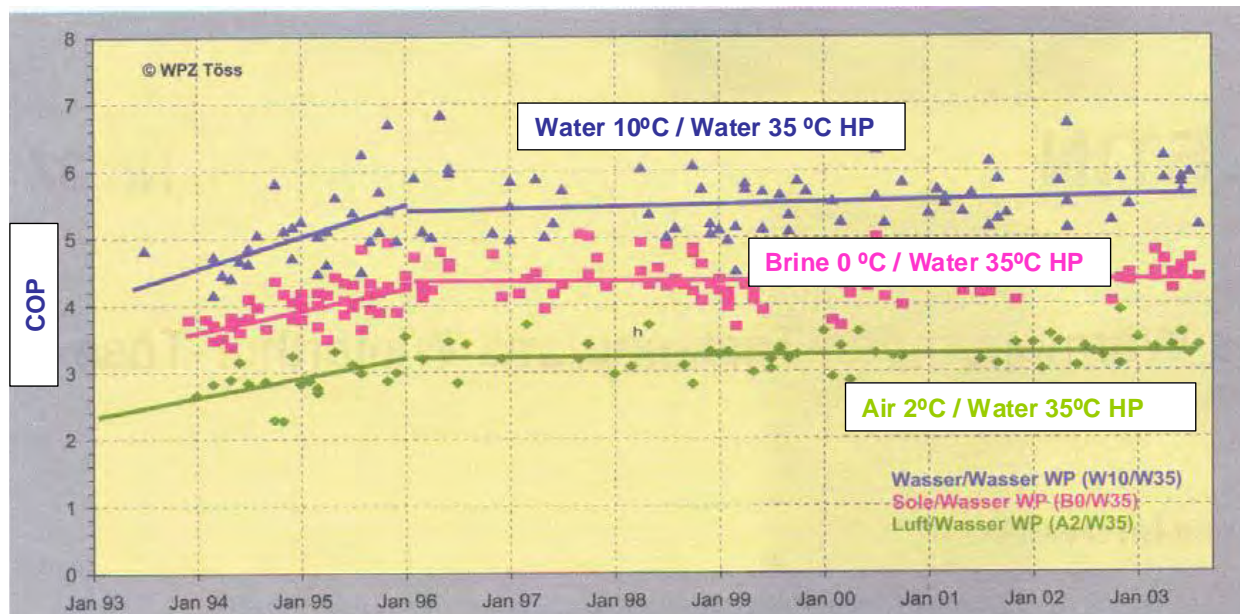

Figure 31. Test results from 1993 to 2003 of water/water, brine/water and air/water heat pumps. Take care that there is a difference from COP (coefficient of performance) to EER (annual energy efficiency ratio)! Source: WPZ Töss, WPZ Bulletin Nr. 37.

An example: A water/water heat pump with a COP of 5.6 needs 1 kWh electricity to produce 5.6 kWh of thermal energy. An air/water heat pump will produce only 3.2 kWh thermal energy.

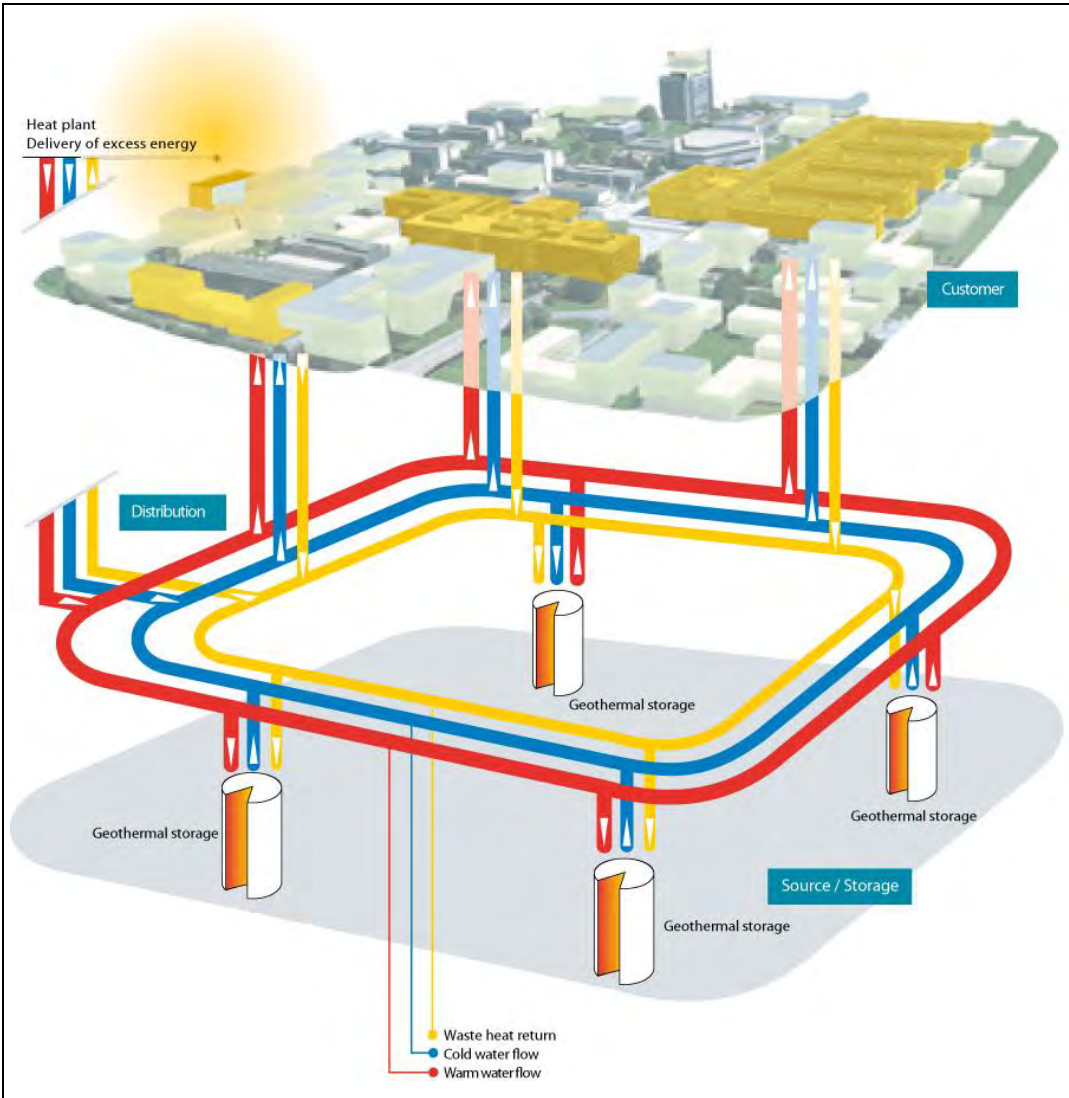

Figure 32. Dynamical geothermal storage with anegy-net; ETH Zurich, Switzerland

4 SPECIAL CONDITIONS IN THE NORTHERN EUROPE

This chapter takes up some conditions, mainly technical ones, in the North European countries that play a role when implementing very low energy houses. In the following, the main differences about climate, traditions around construction of buildings and the economy are reflected.

4.1 North European Climate

The building heat losses and solar gains are a direct function of the local climate, mainly outdoor air temperature and solar radiation. In the following, a broad picture is given to illustrate the differences/similarities of the climatic conditions of the participating countries. This overview covers practically all the Northern Europe, see Figure 33 for the reference weather stations.



Figure 33. Locations of the weather stations used for comparison.

(Source of map: <http://www.online-reisefuehrer.com/basebilder/landkarte-europa.jpg>)

4.1.1 Exterior temperatures

Figure 34 shows monthly average outdoor temperatures for all the locations in Figure 33 and Figure 35 illustrates the average difference between indoor temperature and outdoor temperature during the heating season. The North European conditions are in this comparison related to the standard German climate that best represent a typical Central European climate. The climate varies throughout the Europe, of course, but the purpose of this comparison is especially to relate the Nordic conditions to the typical Central European conditions as these are very often used in the well-known passive house context.

For a better comparison, all the presented climate data are generated with the same method, Meteororm 6.1. The Standard climate for Germany is taken from PHPP 1.6.

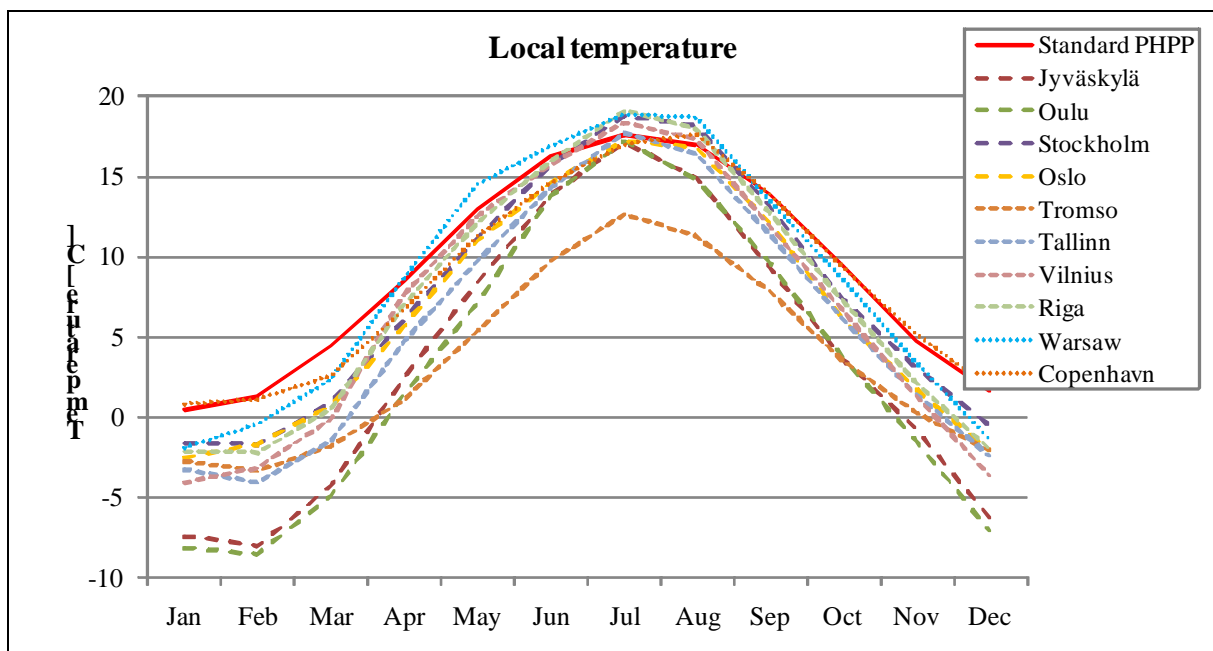

Figure 34. Monthly average temperatures.

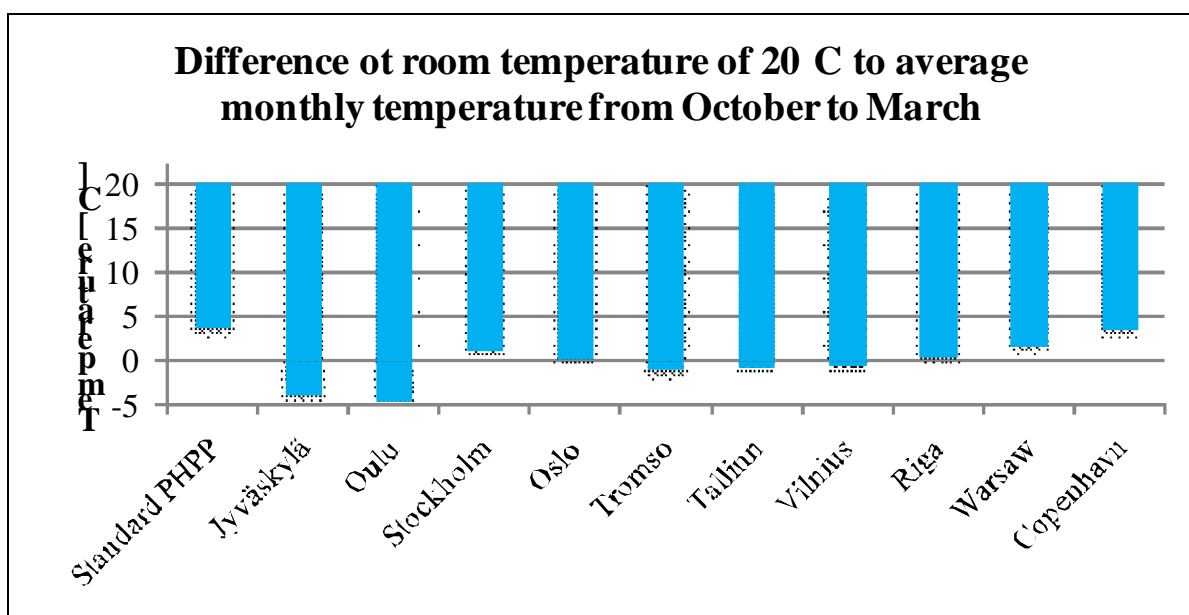

Figure 35. Average monthly temperature differences from October to March.

The diagrams show that the winter temperatures in all selected Northern European locations are lower than the German standard climate. Therefore the heat losses will be bigger in Northern Europe, if the same U-values of the building envelope are being threshold.

4.1.2 Solar radiation

The yearly global solar irradiation on an optimally south oriented façade throughout the Northern Europe is illustrated in Figure 36. The amount of solar radiation varies quite a lot and is not at all a direct function of the latitude: There are equal amounts of yearly solar radiation e.g. in South-Western Sweden and the Eastern Finland.

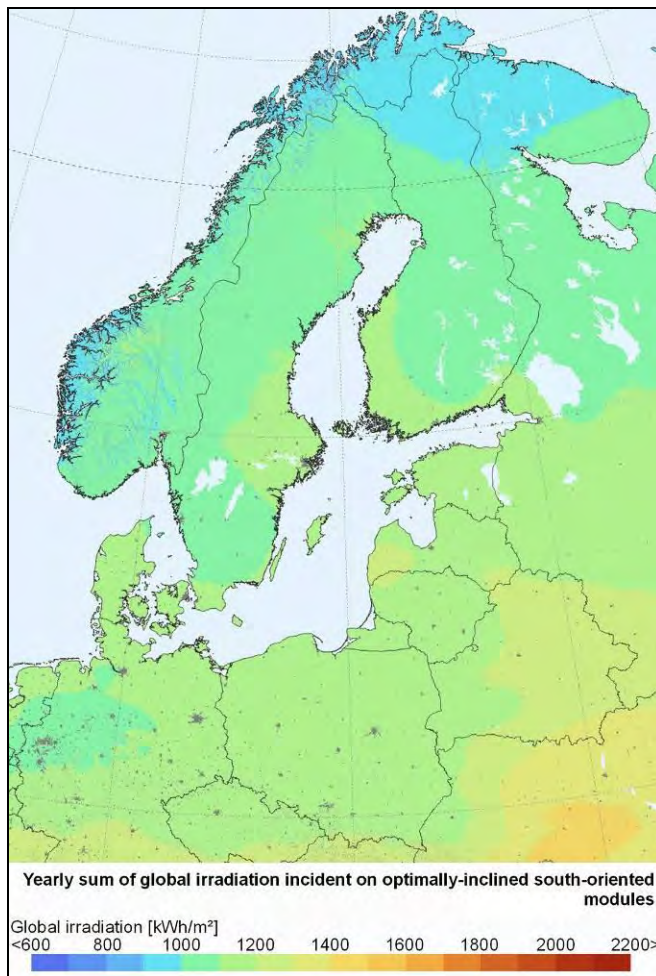

Figure 36. Yearly radiation to the participating countries on optimal oriented modules; Map source <http://re.jrc.ec.europa.eu/pvgis/>

The monthly solar radiation to a south oriented façade is given in Figure 37. The overall picture of this comparison shows that the amount of solar radiation is relatively high in the Northern Europe compared to the Central European conditions. There are 2 main characteristic and mechanisms:

- Especially outside the heating season the solar radiation is higher in all Northern European locations compared to Standard German conditions. In the wintertime, there is much less solar radiation in the Northern part of the North European region.
- The amount of radiation is high, because the sun path is lower in the North and therefore shines quite straight into the south oriented building façade so north.

The lower incident angles, when on northern latitudes, and the longer hours of solar radiation during the summer half of the year, result in more solar radiation on a vertical, south oriented

facade than in Central Europe. If the window area to south is large, effective solar shading must be used in order to avoid over heating, especially in spring and autumn.

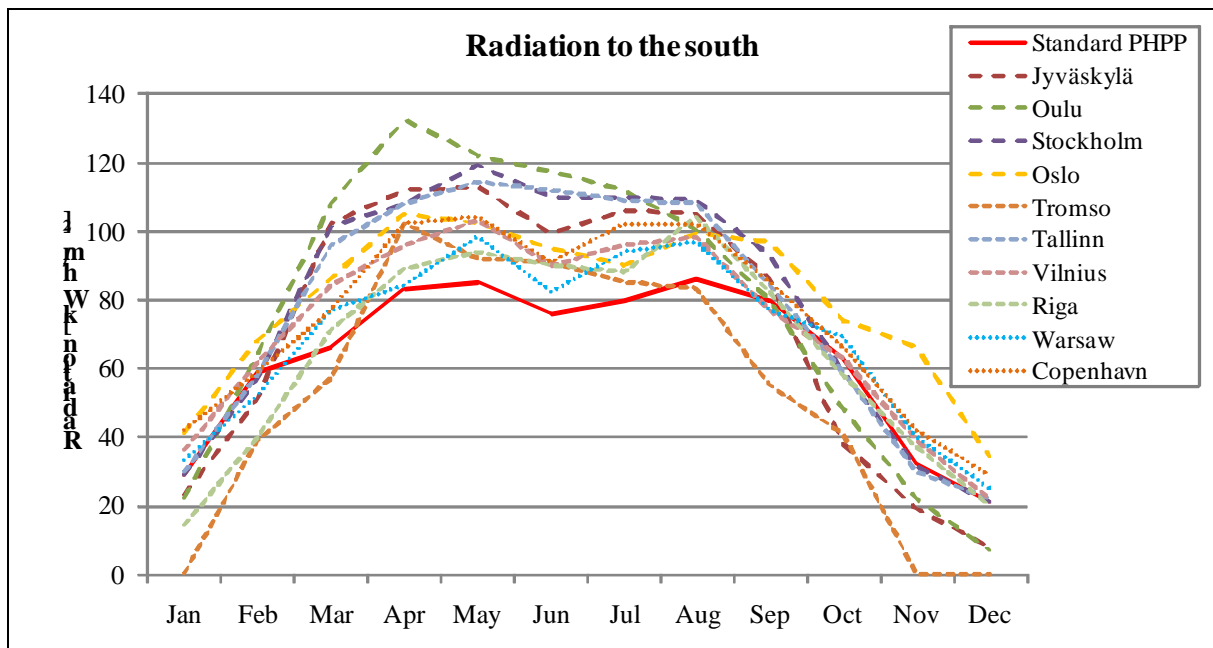

Figure 37. Monthly radiation (kWh/m^2) to a south oriented façade for the selected weather stations

An overview of the distribution of the solar radiation on the facades oriented in the main compass directions is given in Figure 38.

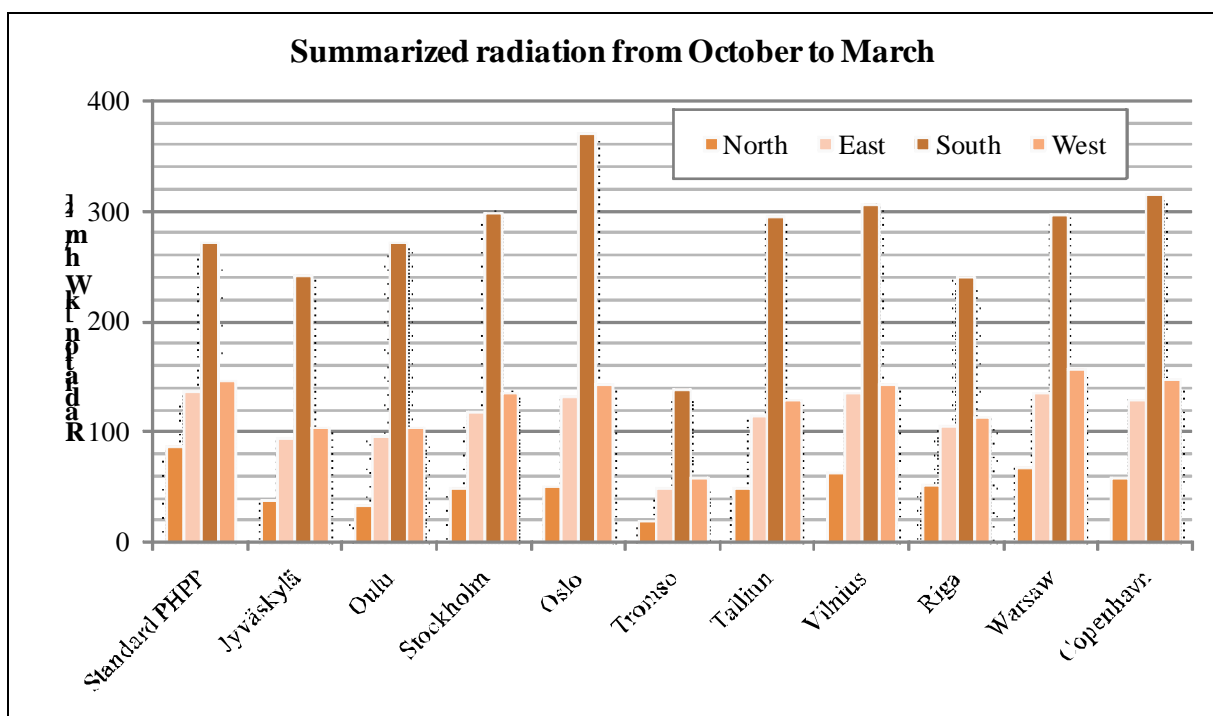

Figure 38. Summarized solar radiation to a facade oriented in all four main directions from October to March for the selected North European weather stations.

4.1.3 Freezing of ground

The low temperature of the ground and especially the freezing ground has in two ways an impact on the very low energy house:

- A frozen underground can damage a building by smelting and changing its density and
- earth-air ground source heat exchanger (earth tubes) cannot work proper in frozen ground.

The area of continuing permafrost is not dominating the Northern Europe and hardly anyone is living in this area, but it exists there (see Figure 39). The seasonal influence of frozen ground is quite strong, however, in parts of Finland, Norway and Sweden and has to be taken into account in the planning process. A well-insulated low energy building will have very low heat loss to ground and therefore the ground around the building is not heated in the same way as it is the case for traditional buildings. An example on the dimensioning frost free depths is given in Figure 40 (for Finland). The depths in this figure are given for unheated buildings and illustrate the worst case, also for a very low energy house.



Figure 39. Permafrost distribution in the Arctic,
Source: <http://maps.grida.no/go/graphic/permafrost-distribution-in-the-arctic>
(Last visited September 7, 2010)



Figure 40: The dimensioning frost free depths for unheated buildings in Finland. Also dimensioning heating degree hours [Kh] are given. F_{50} gives the probability for these degree hours once in 50 years. [15]

4.1.4 Freezing of heat recovery

The freezing of the heat recovery units is a known problem in the cold climates. The freezing increases for increasing heat recovery efficiency: the exhaust air is cooled so much down that the moisture in the air start freezing. The experimental results at the Technical University of Denmark illustrated that already in the relatively mild Danish climate the heat recovery effect will be reduced (see e.g. Figure 41) and there would be some condensation problems on the ventilation ducts and some draught problems around the air inlets, if no action to avoid the problem is taken.

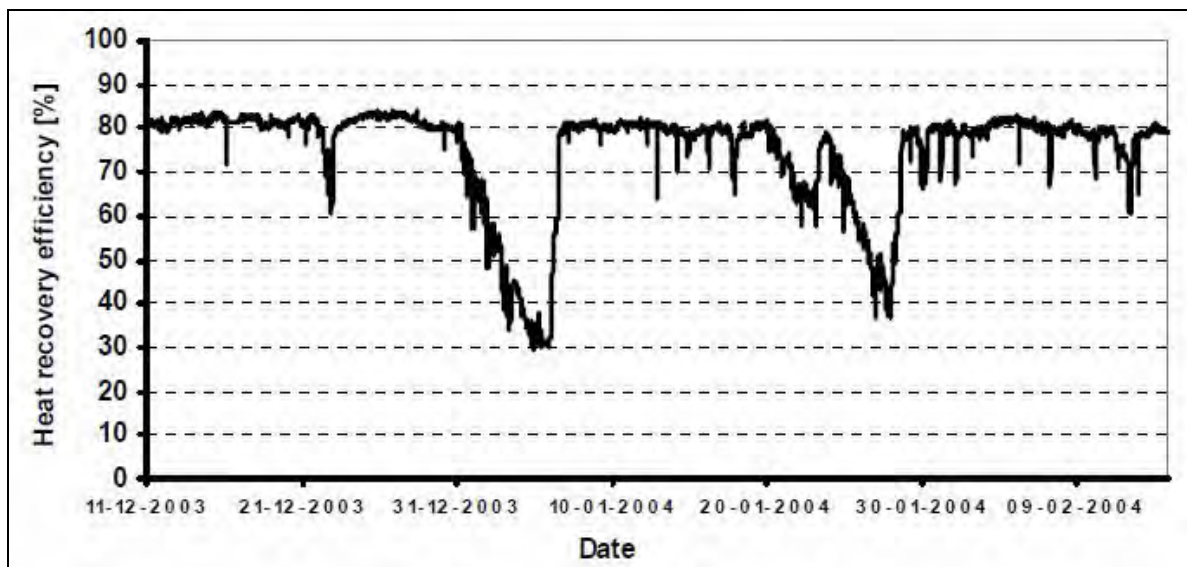

Figure 41. Temperature efficiency of heat exchanger. Typical Danish winter
Source: [7]

The freezing can be prevented by e.g. (disadvantages are given in parenthesis)

- bypassing the outdoor air the heat exchanger (comfort problem because of the cold air)
- preheating the outdoor air (price, more installations)
- moisture recovery / rotating heat exchanger (use conditions are limited)

- closing the ventilation (intake) for short periods (not possible in very airtight buildings)

All this affects, however, also the efficiency of the heat recovery. More about this in solutions for the cold climates (Chapter 5).

A R&D project in Greenland by Technical University of Denmark [8] showed also, that a frozen heat recovery works very inefficient and have a big impact on the energy demand: *“The heat recovery system has in some periods been blocked by ice. Beginning ice formation in the system has had the effect to impair the cyclic change of the order of the two parts of the heat recovery system, so the defrosting function has not been fully functional, and the frosting situation has gotten worse. In October 2006, an insulated box was built around the heat exchanger unit, and an electric heater ensured heating of the air around the box to a temperature that approaches normal indoor air temperature. However this initiative has not eliminated the problem, and the temperature efficiency of the heat exchanger remains around 50% (in some periods only 30%), while the system was expected to have an efficiency of 80%. Wasted energy by insufficient heat recovery (estimate): 30% of ventilation heat loss = approximately 25 kWh/m².”*

4.2 Building traditions

The realization of very low energy buildings requires the fulfilment of the main principles: Minimisation of heat losses and energy consumption, optimisation of the solar gains and substitution the remaining energy needs with environmental friendly energies.

In the earlier sections of this report it was shown, how the heat losses are reduced by using low U-values and the optimized constructions and the solar gains utilised with the over all building design, window orientation and design. However, the building traditions and typical solutions vary from country to country and may turn to be a challenge for implementation of these principles for very low energy houses. Figure 42 shows some typical constructions used in some of the Northern European countries (according to [9]). Detailed information on the actually used techniques and construction solutions will be treated in e.g. WP3.

	Facade Out - In	Floor	Roof	Window Out - In	Construction/ examples
Norway					
Finland					
Norway					
Denmark					

Figure 42. Some examples on thermal envelope details in Northern Europe. The first two rows represent the best practice examples and the other two rows represent the common practice examples [9].

The common practice for heat production and distribution is usually central heating with radiators (generally high temperatures) or floor heating. The energy is produced with oil, gas or electro heater – and many urban areas are connected to the district heat grid.

4.3 Strength of economy

The strength of economy of the different parts of Europe is very different, and in the North European countries, too. See Figure 43 for illustration of the European purchasing power. Any extra construction costs related to realization of the very low energy buildings may play a central role in some economies while the role is non-existing in the strong economies. In order to reduce these barriers for implementation of the energy efficient buildings, it is an advantage to keep the very low energy house on a low technical and therefore also on a low cost level. The HVAC-system has to be as simple as possible, and also easy to maintain. The same goes for the envelope to make it reasonably priced and robust. The economically optimal technical level of the very low energy houses is found by the analysis in another part of this project (WP3) and the barriers are studied by WP4 and WP5.

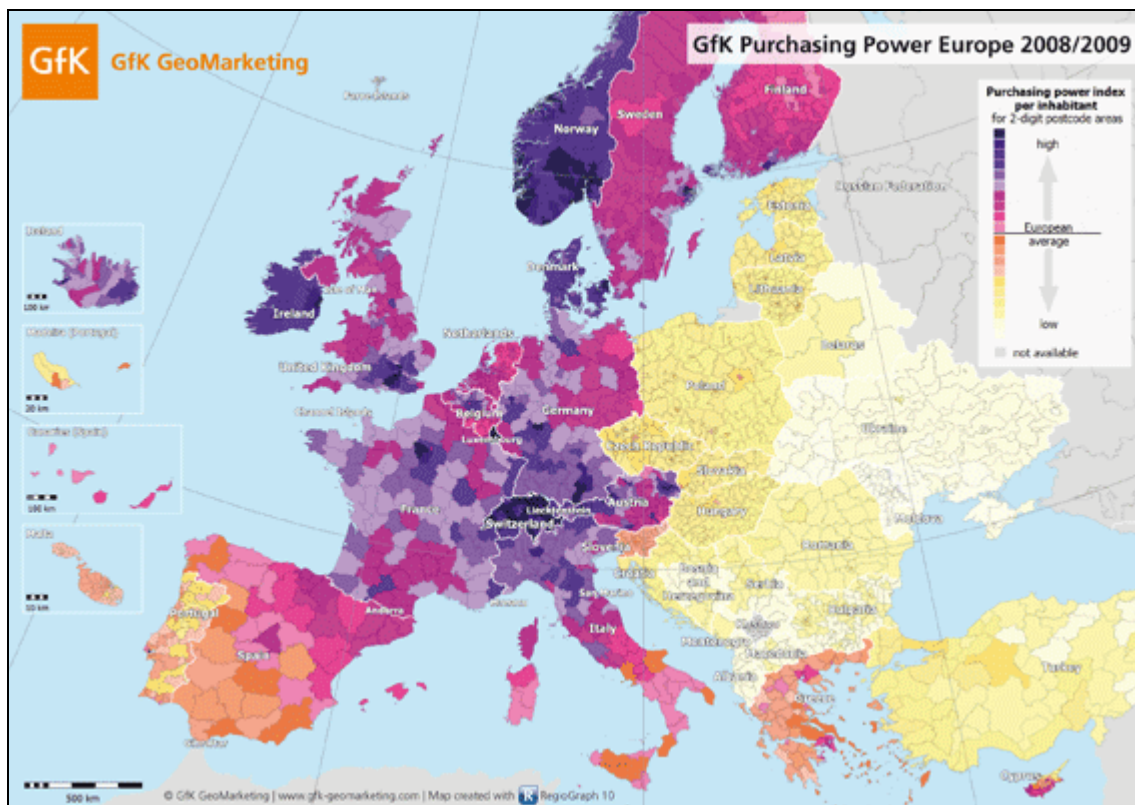

Figure 43. Discretionary purchasing power over Europe in 2008/2009⁴.

Nevertheless, some example conclusions on economical U-values are showed in Table 5. These values are conclusions of a report “U-values for better energy performance of buildings” established by ECOFYS [10]. The report shows economical U-values for 100 European cities. It deals with the most economical U-values for roof, wall and floor including energy prices and material prices (still fulfilling the European Kyoto Agreements).

Table 5. Resulting optimum U-values based on cost-efficiency sorted by country of the ECOFYS report VII [10]

⁴http://www.gfkgeomarketing.com/fileadmin/gfkgeomarketing/en/img/press/purchasing_power_europe_2008_2009.gif

U-values [W/m ² K]		WEO reference			Peak price scenario		
City	Country	wall	roof	floor	wall	roof	floor
Copenhagen	Denmark	0.19	0.16	0.24	0.16	0.13	0.21
Aalborg	Denmark	0.18	0.15	0.23	0.16	0.13	0.21
Tallinn	Estonia	0.19	0.17	0.23	0.17	0.14	0.21
Helsinki	Finland	0.18	0.15	0.22	0.17	0.13	0.20
Oulu	Finland	0.17	0.14	0.21	0.15	0.12	0.18
Ivalo	Finland	0.15	0.12	0.19	0.14	0.11	0.17
Riga	Latvia	0.20	0.18	0.25	0.17	0.15	0.22
Klapeida	Lithuania	0.21	0.18	0.26	0.18	0.16	0.23
Vilnius	Lithuania	0.20	0.18	0.25	0.17	0.16	0.22
Bergen	Norway	0.21	0.17	0.25	0.18	0.15	0.22
Oslo	Norway	0.19	0.15	0.22	0.17	0.13	0.20
Trondheim	Norway	0.18	0.14	0.22	0.16	0.13	0.19
Tromsö	Norway	0.17	0.14	0.21	0.15	0.12	0.19
Hammersfest	Norway	0.17	0.13	0.20	0.15	0.12	0.18
Swinonjście	Poland	0.21	0.19	0.28	0.19	0.17	0.23
Poznan	Poland	0.21	0.19	0.26	0.19	0.17	0.23
Warsaw	Poland	0.21	0.19	0.26	0.19	0.17	0.23
Gdansk	Poland	0.21	0.18	0.26	0.18	0.16	0.23
Goteborg	Sweden	0.20	0.17	0.25	0.18	0.15	0.22
Stockholm	Sweden	0.20	0.16	0.24	0.18	0.14	0.22
Umea	Sweden	0.17	0.14	0.21	0.15	0.12	0.18
Lulea	Sweden	0.17	0.13	0.20	0.15	0.12	0.18

This economical “best price” U-values are calculated by comparing the capital cost for the insulation and the energy cost savings about the insulation (see Figure 44). Due to the shape of the cost curves around the optimum U-value (insulation thickness) it is possible to go beyond the calculated optimum with still reasonable cost efficiency, leading to higher energy and CO₂ savings. So the values in Table 5 are in that way the maximum values, which can be improved without huge extra expenses in according to the slightly increasing curve.

A note: The buildings in this Ecofys –study are not “optimised” as very low energy buildings and the study only deals with the opaque envelope.

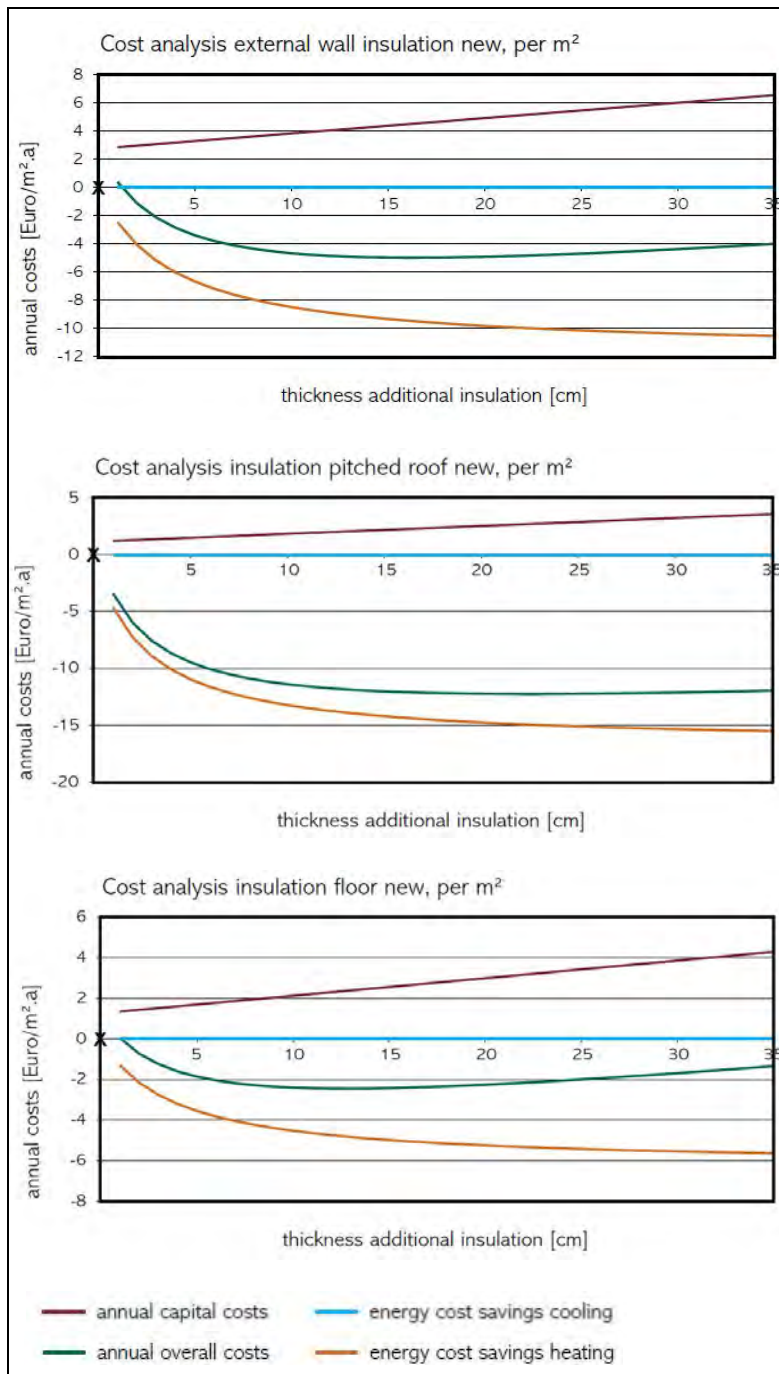

Figure 44. Cost efficiency insulation of external walls price scenario “WEO reference” from Stockholm ECOFYS report VII [10]. Note: The optimum is highly dependent on the used energy price scenario.

5 INFLUENCE OF THE SPECIAL CONDITIONS ON THE BUILDING DESIGN

The purpose of the buildings is to give good indoor environment for the users of the buildings. The approach in this chapter is the influence of the Northern European climatic challenge on the very low energy building design and the solutions on the building envelope and building services. The focus in this chapter is on the principal and simplified solutions that partly are illustrated with calculation examples.

5.1 The building envelope and energy

As a base for the calculation, two already rather optimised low energy buildings were defined: a single family house and a multi-family house. Detailed information can be found in another report of this project D4 “Energy-demand levels and corresponding residential concept houses and the specific challenges of very low-energy houses in colder climates”.

5.1.1 Building envelope

The Northern European exterior climate and its variation are in the following used for an investigation of its influence on the resulting heat load and heat demand and the necessary average U-values.

There are following 2 types of thresholds for the calculations, both for the single family house and multi-family house that are studied separately:

1. The U-values are fixed
→ heat demand and heat load are variable (Figure 45 and Figure 46)
 2. The heat demand is fixed
→ U-values are variable (Figure 47 and Figure 48)
-

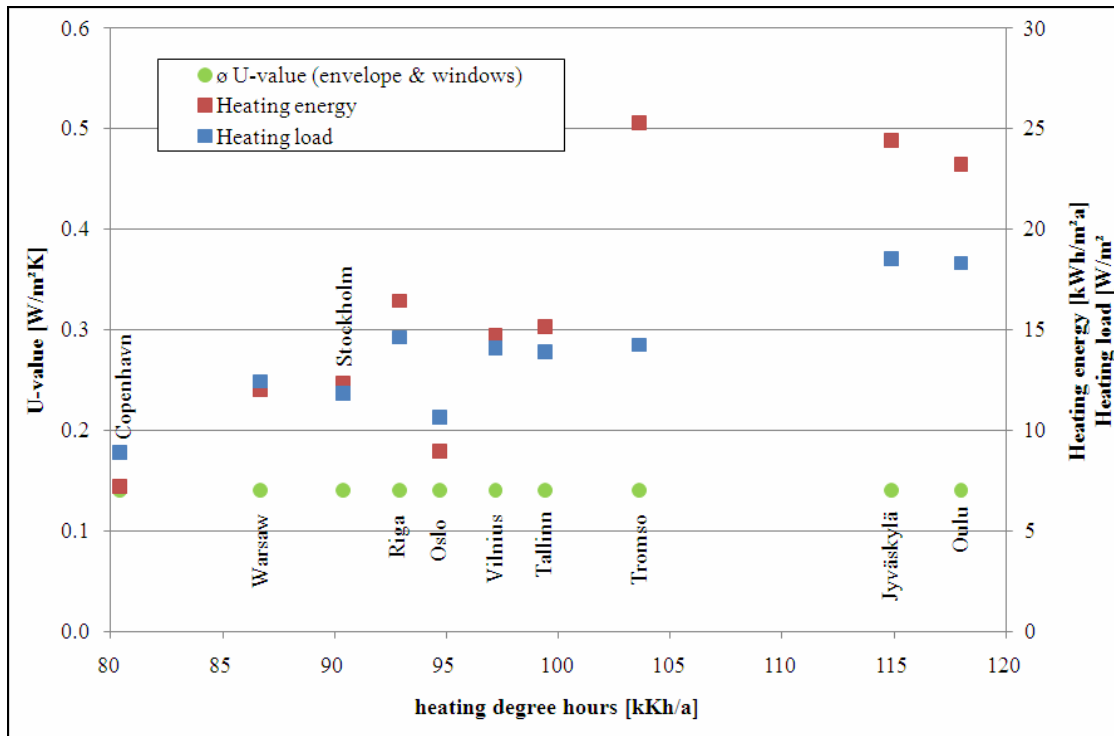

Figure 45. Comparison of the single family house in the different climates. Envelope U-values are kept constant. U-value is an area weighted mean value of windows and opaque parts.

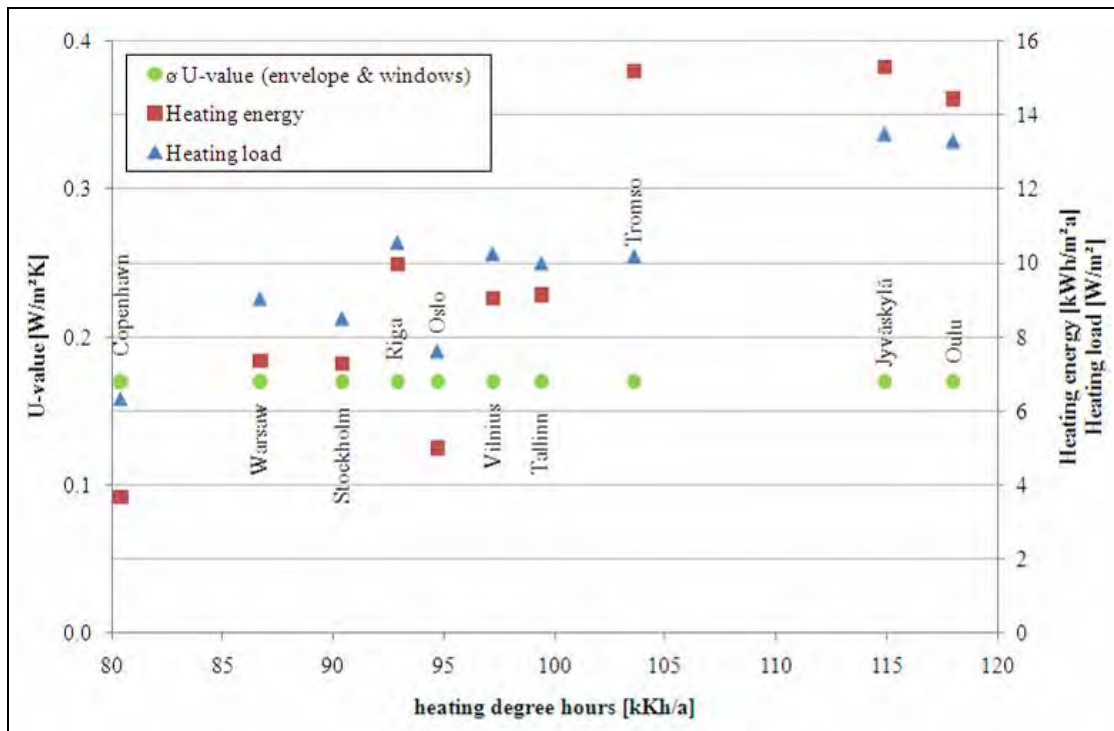

Figure 46. Comparison of the apartment house in the different climates. Envelope U-values are kept constant. U-value is an area weighted mean value of windows and opaque parts.

The calculations of the two building types showed that the space heat demand varies from 7 to 25 kWh/m²/y (single family house) and from 4 to 16 kWh/m²/y (multi family house) depending on the climate.

To compare these conditions better, the space heat demand was fixed to around 15,4 kWh/m²/y and the U-values of glass, frame and opaque constructions were changed.

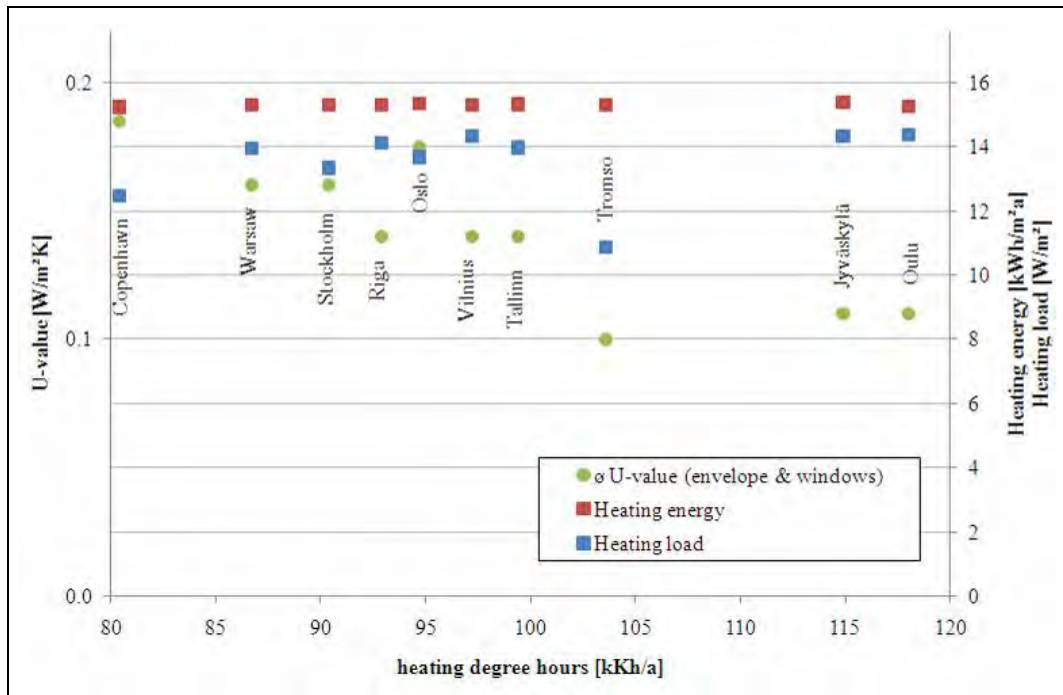

Figure 47. Comparison of the single family house in the different climates. The heat space demand is kept constant and the envelope U-values are varied. U-value is an area weighted mean value of windows and opaque parts.

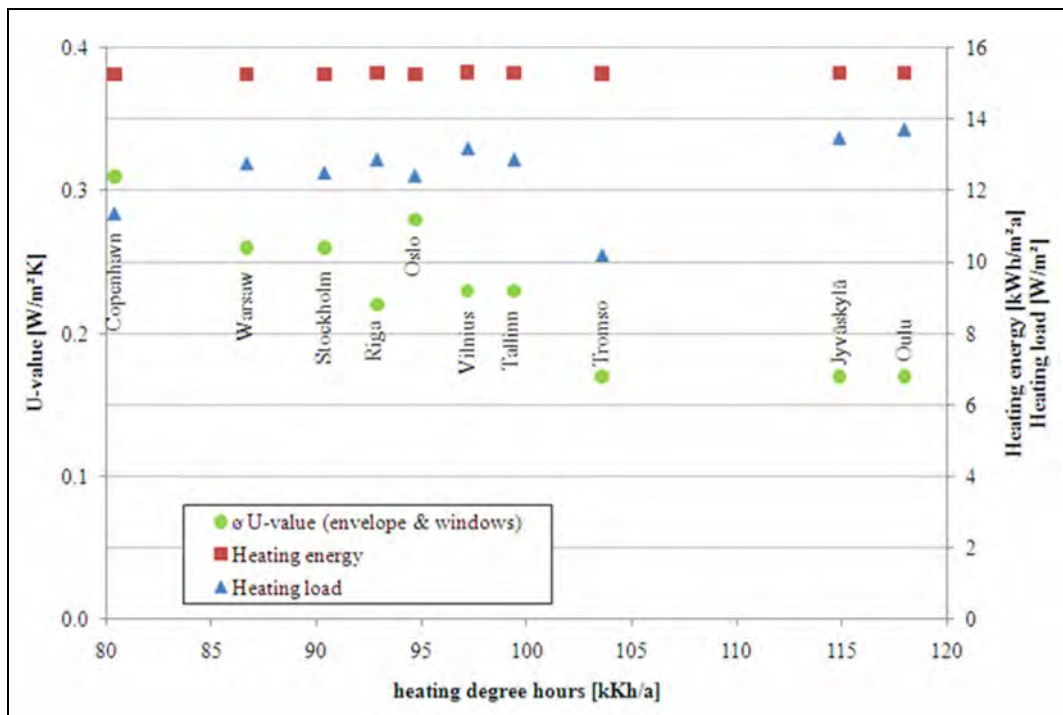

Figure 48. Comparison of the apartment house in the different climates. The heat space demand is kept constant and the envelope U-values are varied. U-value is an area weighted mean value of windows and opaque parts.

Keeping the space heat demand (heating energy) constant for all the weather stations, the needed variation in average U-values (including windows) is obvious: For increasing heating degree hours the U-values have to be lower in order to achieve the same heat demand. The variation for a single family house in the studied locations in Northern Europe is 0,1-0,19 W/(m²K) This means that the weighted U-values need to be halved in Jyväskylä, Oulu and

Tromsø compared to U-values for Copenhagen and Oslo. These values relate also quite directly with the solar gains and the outside temperatures.

5.1.2 Window as loss and gain-factor

The only envelope component, which can be optimised in two directions – smaller heat transmission or smaller solar transmission – is the window. To get a better view on the influence of the window characteristics on the heat balance an EN 13790 calculation model was used for the studied climates. The model of the single family house used in the previous comparison was a bit simplified. The high relation between g-value and U-value was used like given in Figure 49.

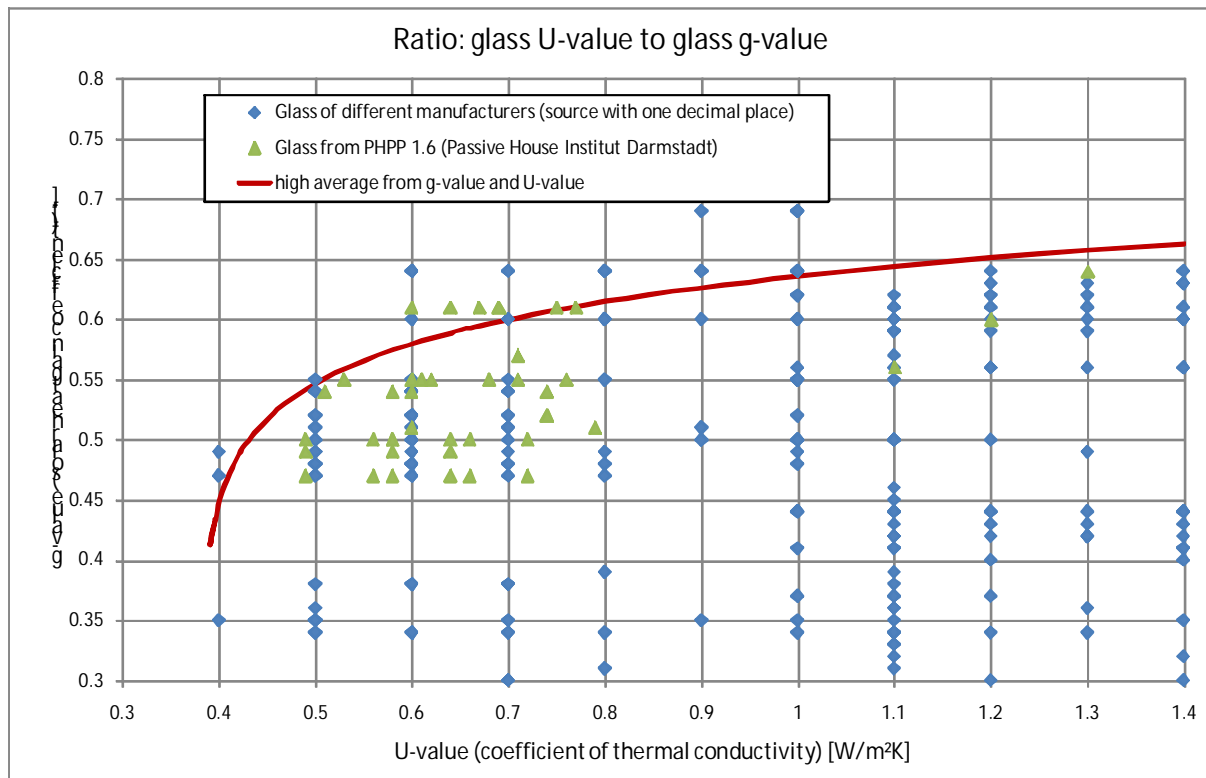

Figure 49. Relation of g-value and U-value for window glass (Figure 28) with an average relation curve on a high level

Some examples of the calculation results are shown in Figure 50. The total ratio of the glass area to the floor area is for this example building ($TFA^5 = 172 \text{ m}^2$) between 1,5 % and 11,5 %, depending on the glass area.

Results for all studied weather stations and the four main compass orientations are found in Appendix. Calculations were performed according to EN 13790.

This overview shows that in most of Northern Europe the space heat demand decreases if the glass area to the south gets bigger depending on the quality of glass. The breaking through would be in Copenhagen with a glass U-value around $1,3 \text{ W/m}^2\text{K}$, in Vilnius around $0,8 \text{ W/m}^2\text{K}$ and in Jyväskylä will it start under $0,4 \text{ W/m}^2\text{K}$. These values are linked with the frame area and installation / spacer thermal bridges. Because of the strongly decreasing curve

⁵ TFA= treated floor area

from g-value to U-value for low g- and U-values (see Figure 49) the 0,5er glass gets for all directions and climates better results than the 0,4er glass.

For the north orientation it is not possible – yet with very good windows – to get a better heat balance when using bigger glass area. The west and east orientations are much better than north, but it is still not possible to get a positive energy balance with glass U-values over 0,4 $\text{W/m}^2\text{K}$ (still including additional thermal bridges and frame). However, the losses are rather small.

It is extremely important in this context – when optimizing the main window areas to south – carefully to analyse the possible overheating in the summer time. The effect of external blinds, building heat capacity and internal gains has to be calculated and taken into account in the design.

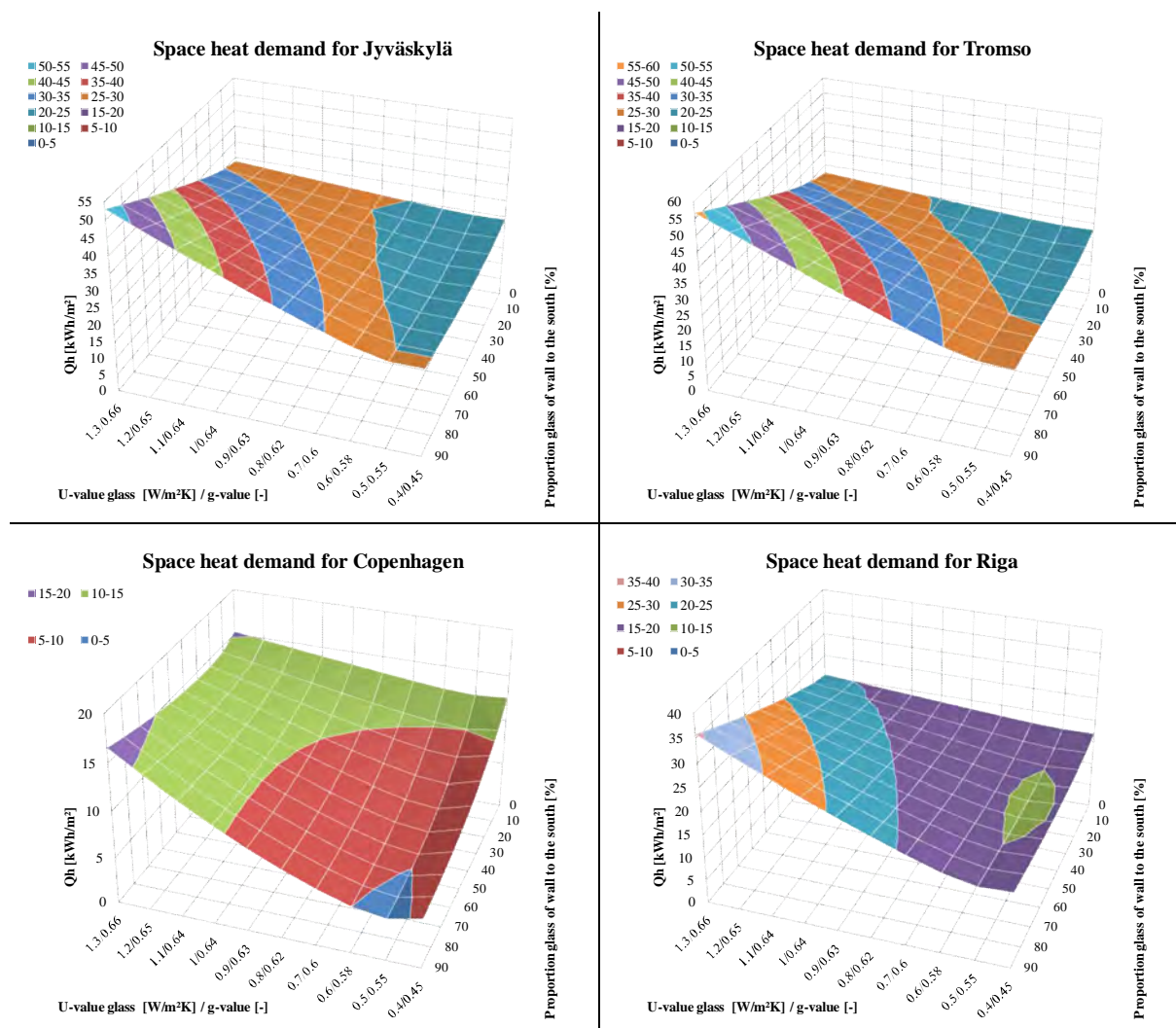

Figure 50. Space heating demand of the single family house (kWh/m^2) as a function window g- and U-values (left horizontal axis) and the ratio of the window area to façade area (right horizontal axis). South oriented windows are studied. Fixed window size to every other orientation: N=1%, E=6% and W=6%.

5.1.3 Interior surface temperatures

Cold interior surfaces can result in draught, growing of mould and worse condensate. Because of the low U -values of the constructions, there are almost no such problems in very low energy buildings. In addition to the well insulated constructions, these buildings are built as far as possible without any thermal bridges. A thermal bridge calculation will show if the critical temperature factor, f_{Rsi} value, is over 0.7, which it should be for no probability for moisture problems (see chapter 3.1.2). A typical value is $f_{Rsi} = 0,98$ in very low energy houses.

Regarding windows, draught will normally not be a problem for a 2m high window when using a 3-layer glass, corresponding to $U_g < 0,8 \text{ W/m}^2\text{K}$, and when the outdoor air temperature stays above 0°C . The colder the climate, the lower must be the acceptable U_g , typically under $0,5 \text{ W/m}^2\text{K}$, see Figure 51.

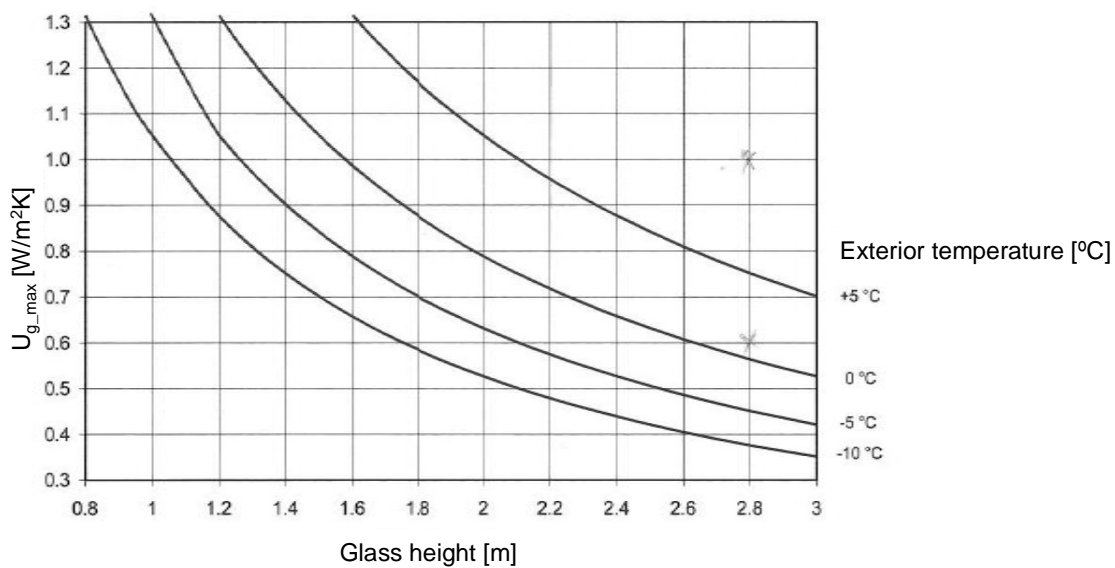

Figure 51: The influence of the window height and the outdoor temperature on the necessary U_g -value in order to avoid draught. From [16]

5.2 Solving the specific challenges in colder climates

Some of the central impacts of the cold climate to the very low energy house presented earlier in this report are here treated from the technical solution point of view.

5.2.1 Freezing of heat recovery

There exist many solutions to keep the heat recovery ice free. But at least in a very low energy house which is air tight not all of the known solutions are useable. Functions like “switch off outside air” or other features which causes misbalance in the air flow and differences of pressure from outside to inside must be avoided.

To prevent freezing problems in heat recovery units it is recommended to use a ground-coupled heat exchanger to preheat the outdoor air. There is a small effect on the heat recovery rate, too, but the main advantage is that the energy for defrosting can minimized or left out. There are two common systems: earth-air ground source heat exchanger (earth tubes) or earth-brine ground source heat exchanger. The following figures explain how these are working.

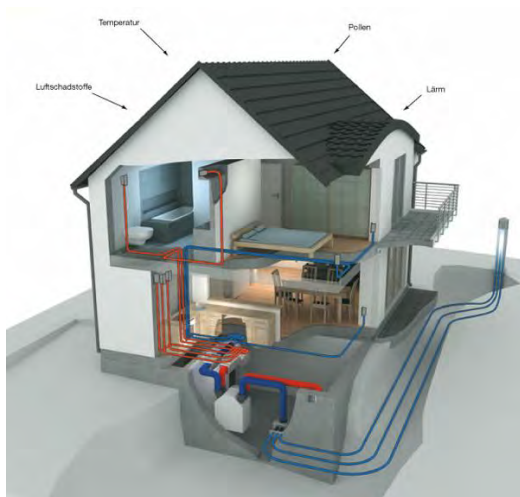

Figure 52. Earth-air ground source heat exchanger (earth tubes): The intake tower filters air and draws it into the loop where its temperature is modified by the surrounding earth. This air is then passed to the inside of the dwelling via the heat recovery ventilation unit. (Source: Zehnder Comfosystems)

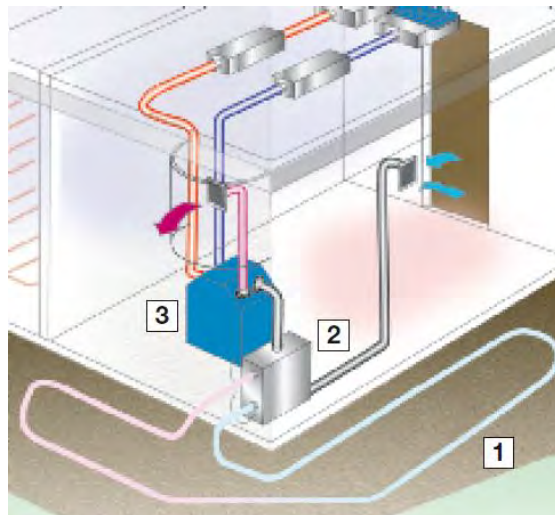

Figure 53. Earth-brine ground source heat exchanger: A brine filled ground loop (as geothermal probe or below the surface) is connected to a water/air heat exchanger which passes the energy of the brine to the ventilation air. (Source: Zehnder Comfosystems)

Some other solutions to prevent ice or defrosting the heat recovery were discussed in [7]. But the most of the shown examples makes the ventilation unit more complex and also expensive.

So the simply recommendation would be the use of a ground source heat exchanger and after it a high efficient heat recovery. If the temperatures after the liquid-to-air heat exchanger are too low for a plate heat recovery, a thermal wheel which also transfers humidity is then the best solution. Examples of thermal and humidity heat exchanger wheels are running fine by -20°C without freezing (e.g. HomeVent from www.hoval.com).

Another way to protect the heat recovery against freezing problems is to use a combined humidity and heat exchanger. The excess humidity from the warm extract air is removed and added to the dry supply air before the heat exchange. In this way there is no water that can freeze. The limiting conditions are around -15°C to -20°C – depending on the used ventilation unit. These units are typically rotating systems, which have been working reliable. Also other types of combined heat and moisture exchangers have been developed and introduced. Some examples of heat recovery units are given in Figure 53 and Figure 54.

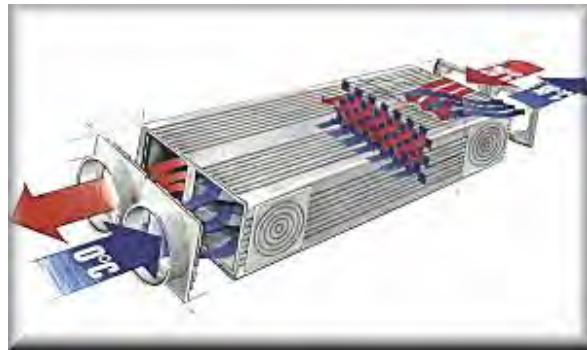

Figure 54. Ventilation unit as rotating system with a combined humidity and heat exchanger. (Source: Hoval)

Figure 55. Ventilation unit as plate heat recovery system. (Source: Paul)

A short overview over the existing heat recovery systems is given in Table 6:

Table 6. Overview on the different heat recovery systems from exhaust air (based on [12]). The last 3 types (*) are not recommended for use in residential buildings in the Northern Europe, which is the subject in this report.

Type:	Remarks:
plate heat exchanger (as HRV ⁶)	Standard heat exchanger for ventilation units for single family and apartment houses. Special measures for frost protection necessary.
plate heat exchanger (as ERV ⁷)	Plate heat exchanger which also exchanges humidity. Cheap variants made by paper based permeable filter are not viable. Special membranes are recommended. Just a few products available. Because of the humidity transfer there is a higher frost protection.
thermal wheel (as HRV)	Standard heat exchanger for ventilation units for apartment houses. If the fans are wrong positioned, this results in air leakages.
thermal wheel (as ERV)	Thermal wheel which also exchanges humidity. If the fans are wrong positioned, this results in air leakages. Small and bigger units available. Because of the humidity transfer there is a higher frost protection.
heat pipe (*)	Expensive system with quite low heat recovery efficiency.

⁶ Heat Recovery Ventilators only recover sensible energy (heat transfer).

⁷ Energy Recovery Ventilators recover sensible and latent heat (moisture), transferring heat and moisture from the exhaust air flow to the incoming outdoor air flow.

run-around coil (*)	Useable when exhaust air and fresh air ducts are not together or exhaust air and fresh air must be absolutely isolated from each other. Quite low heat recovery efficiency.
accubloc (*) ⁸	Innovative system but expensive and hardly useable for a central ventilation plant in an apartment house: There is air leakage (air flow flows in both ways over the “accubloc”) and therefore possible odour transfer.

5.2.2 Limited potential for heating by supply air

The air has a relatively low heat capacity and sets therefore a physical limit for the heating of the supply air. The maximum heat effect limited by the air flow can be calculated in the following way:

$$V' \times \Delta t \times c_{p,Air} \times \rho_{Air} = V' \times \Delta t \times 1.005 \text{ kJ}/(\text{kg K}) \times 1,15 \text{ kg}/\text{m}^3 / 3,6 \text{ Wh}/\text{kJ} = V' \times \Delta t \times 0,32 \text{ Wh}/\text{Km}^3$$

$$\rightarrow \text{with } 25^\circ\text{K} \rightarrow V' \times 8 \text{ Wh}/\text{m}^3$$

$$\rightarrow \text{with } 150 \text{ m}^3/\text{h} \rightarrow 1204 \text{ W} = 1,2 \text{ kW!}$$

With a floor area of 100 m^2 the resulting average specific heat load become $12 \text{ W}/\text{m}^2$. Even the optimised single family and apartment houses show in the northern climates results above $12 \text{ W}/\text{m}^2$. Furthermore, this calculated value is an average. Typically the heat load of corner rooms not close to the heat coil have

- a bigger heat loss due to the higher envelope ratio to the floor area and
- the heat loss over the supply air duct reduces the local heat load.

Therefore, for every room the balance of needed heat and heat supply by including heat losses over the duct and air volume have to be calculated.

5.2.3 Freezing of ground

As the result of the sub-zero winter temperatures in most parts of the Northern Europe, a special attention has to be paid into the foundation system design. The low exterior temperatures combined with the relatively low heat losses to the ground from a very low energy house compared to a traditional building can result in frost damaged buildings if the insulation is not dimensioned correctly.

There are different possibilities to solve this:

- Locate the building on bedrock or other soil types that have no risk of ice deformation. e.g. gravel or sand.
- Use bearing piles and end them below the ice rich soil
- Add sufficient perimeter insulation and design the size and thickness with dynamical simulations.

⁸ Accubloc is a heat exchanger, where two thermal capacities are alternating between the outdoor air or exhaust air flow – and get cooled down or heated up by the thermal mass.
<http://www.polybloc.ch/pdf/07%20Hochleistung-%20WRG%20accubloc.pdf>

The existing guidelines for dimensioning the perimeter insulation are generally not updated for very low energy buildings. Therefore qualified design, e.g. with dynamic 2D-simulations is necessary. The purpose of these simulations is to proof that the ground under the building – i.e. the pressure power field of the building – never freezes under the given design conditions [15]. An example of such calculations is given in Figure 55 (illustration of the setup and results for a borderline -case) and in Figure 56 showing the used exterior temperature and resulting temperature in the outermost corner of the foundation.

Figure 56. An isotherm view of the results around 1st of February after dynamic 2D thermal simulations of the temperature field around a very low energy house. Also the heat flux – density and direction – is given with arrows. The 0 degree –line goes from the left down corner of the foundation. This example design would be just acceptable.

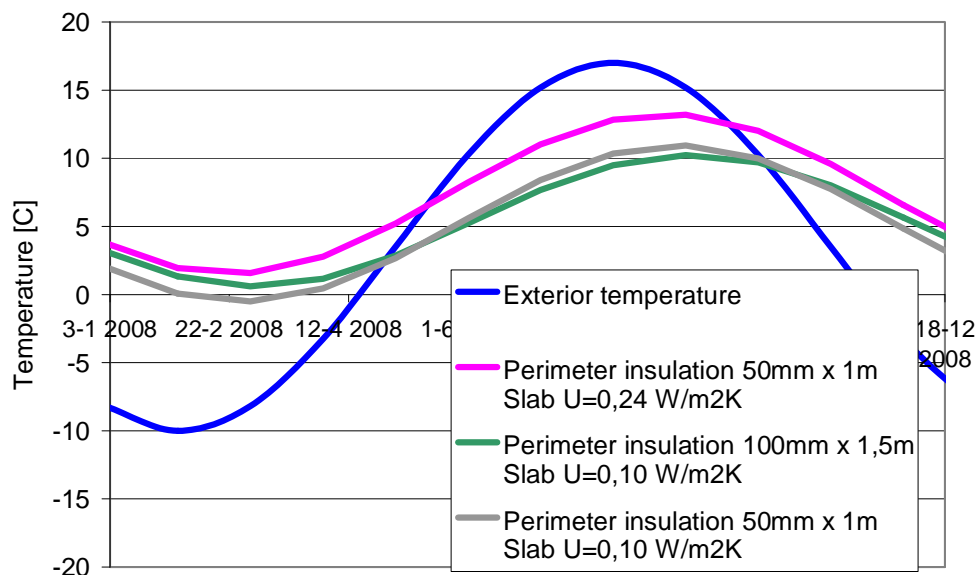
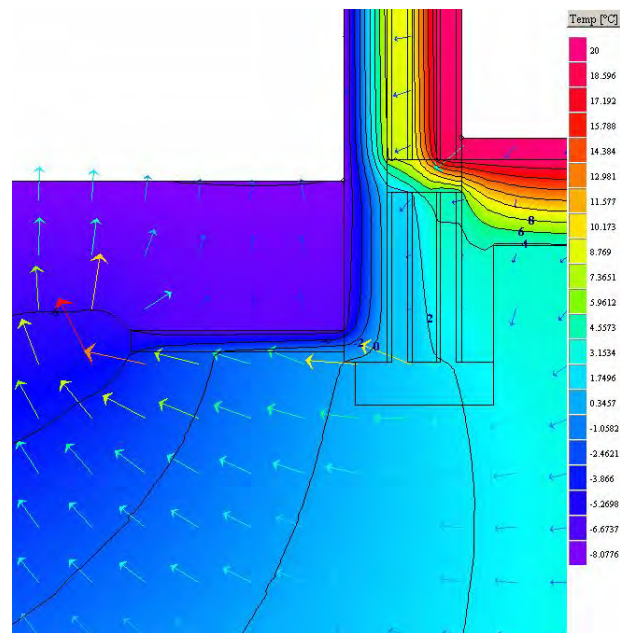

Figure 57: Monthly average exterior temperatures and resulting temperatures in the outermost corner of the foundation with different perimeter insulations. The conventional solution for the slab on ground ($U=0,24 \text{ W/m}^2\text{K}$) is compared with a very well insulated slab ($U=0,1 \text{ W/m}^2\text{K}$). The conventional perimeter insulation will result in insufficient frost protection of the very low energy house and more than doubling of the perimeter insulation is needed.

If operating in the area of permafrost, systems like thermosyphon foundations⁹ can keep the ground frozen during the life span of the building. Over the last 50 years several types of thermosyphon foundations have been developed and used in Alaska and Canada. These consist of vertical cooling tubes and piles, sloping cooling tubes and flat looped tubes.

Earlier in this report there were presented systems which protect the heat recovery from frost and the filters from too much humidity:

1. earth-air ground source heat exchanger (earth tubes) or
2. earth-brine ground source heat exchanger.

Number 1 is not usable when the ground around the tubes freezes. So a possible way is to use earth-brine (number 2) like it is used in couple of R&D projects in Finland (Vantaa passive house and Valkeakoski low energy house projects described in [11]). There are already control units on the market which work autonomically. Find also more information about heat recovery in cold climates in chapter 5.2.1.

Figure 58. A liquid-to-air heat exchanger that transfer heat from the brine to the incoming air by the heat coil.

Attention: The steam-proof heat insulation of the cold liquid and air pipes, the outlet for condensing water complete with siphon, and the pump control unit were still missing in this picture! (Source: <http://www.sole-ewt.de/index-e.html>; last visit: 07.09.2010)



⁹ <http://www.pws.gov.nt.ca/pdf/publications/Thermosyphon%20Foundations%20in%20warm%20permafrost%20.pdf>

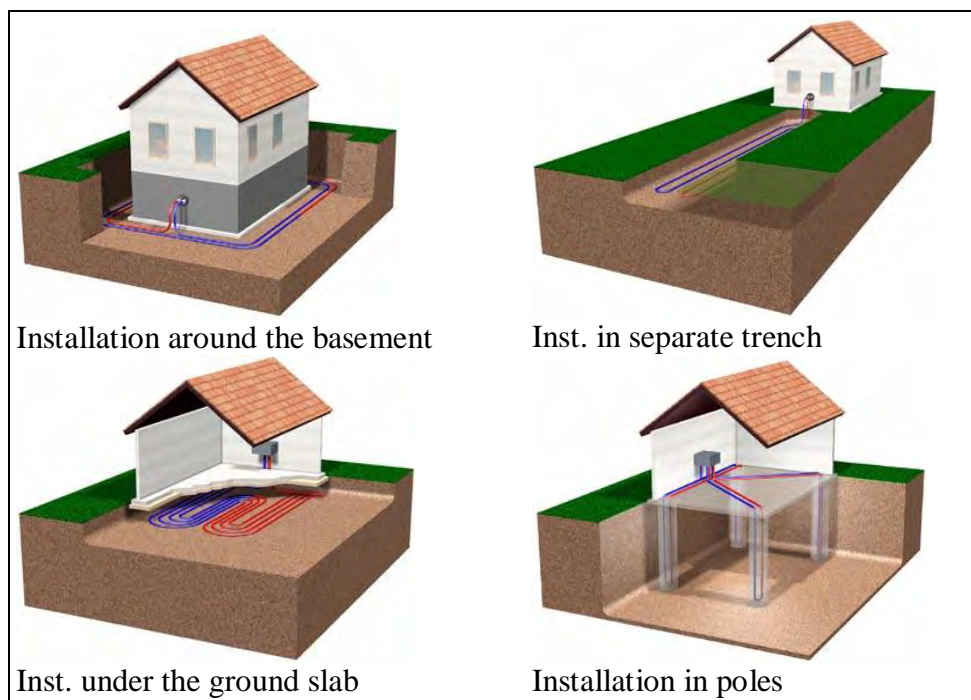

Figure 59. Brine pipework lay-out. Different ways in according to the building type and conditions (Source: <http://www.sole-ewt.de/index-e.html>; last visit: 07.09.2010)

5.2.4 Summer situation

The focus in designing very low energy houses in the North European climates is naturally on the winter situation. However, to avoid any energy to be used for cooling needs, also the summer situation in a very low energy building must be as carefully designed as the winter situation. The experience documented for example in [13] shows that there is for a standard residential building no problems about too high temperatures through the summer in a very low energy building. Standard means that there is reasonable glass ratio to the façade, sufficient thermal heat capacity, some external shadings and it is possible to use cool nights for cooling.

If the summer conditions are not taken account consequently in the design phase, e.g. external blinds are missing; the indoor temperatures can become too high in warm sunny days. The indoor climate of some of the first passive houses in Denmark has been monitored and the results show temperatures above 26°C in some houses during July. The users experience this as a very unsatisfied indoor climate [14]. The use of external variable solar shading – typically blinds – is very common in Europe but not in Northern Europe. Nevertheless, for a very low energy house with optimised window area and orientation, external blinds are as important as a good ventilation heat recovery rate.

5.2.5 Electrical appliance

In a residential building, a big part of the energy is used for home appliances and lighting. The case is similar when relating to heating in standard new buildings and the primary energy demand. In comparison, the electrical use for appliances and lightning in very low energy buildings is usually bigger than the energy use for heating.

The European Union introduced the white goods and lighting energy labelling scheme in 1995. Over time the label has been extended to several types – at least in summer 2010 also TVs.

In order to reach also the primary energy targets of very low energy buildings categories A, A+ and A++ home appliances must be recommended. A lot of possible solutions are showed on www.topten.info and in www.sparel.dk (very comprehensive data bases, but only in Danish).

5.3 Strength of economy, price of buildings

In the text above a lot of possibilities are presented to design a very low energy house. In some cases it is possible even without any additional expense. Some studies document, e.g. [] that the variation in the building costs typically depend on other issues than energy efficiency. The main part of the task to save costs is to do the right decisions at the right time. It is very important that the design team and the owner decide on first stage the way to go. Big changes in the concept are according to experience very expensive. Figure 59 illustrates the trends for costs and the freedom of decisions during the life cycle of a building.

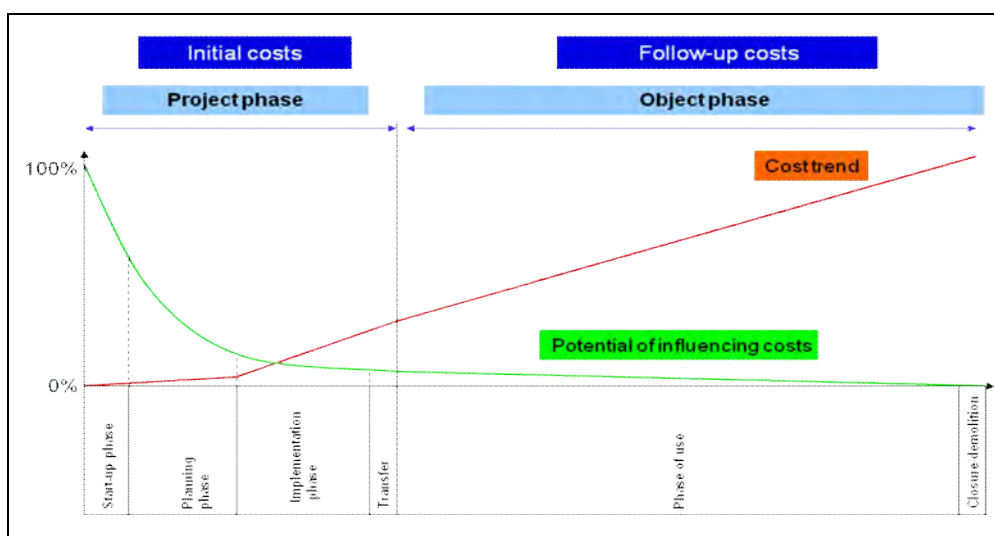

Figure 60. Influencing costs over a buildings total life-cycle
Source: CEPH Course, Passive House Institute, Darmstadt

6 SUMMARY OF THE PRINCIPLES FOR VERY LOW ENERGY BUILDINGS IN THE NORTHERN EUROPE

A summary of a design rules for an applicable very low energy building in Northern Europe is given in this chapter.

6.1 Basic design rules

The basis for these recommendations is the general guidelines and the performed parameter variation calculations for a very low energy building described in this report. The calculated ranges (e.g. U-values) and other recommendations for the single family house and the apartment building are based on the following basic design rules, other reports and experience.

Opaque envelope: The U-values can theoretically vary a lot, totally depending on the whole building design, the energy targets and the local climate. However, the lower the U-values, the lower the heating energy demand. In Table 7 and Table 8 this range is presented for single family house and for a apartment house. The maximum U-values were taken from the ECOFYS report VII [10], see Table 5. The wall U-value was chosen from [10] because it also represented an average of ground and roof. The lowest U-value was calculated as a minimum for the studied buildings to fulfil the international passive house standard.

Windows: The window is the only part of the house, which has an effect both to the losses and the gains (with U-value / g-value). The model calculations in chapter 5.1.2 showed that even in the coldest and darkest climates investigated, an orientation to the South is preferable. Window orientation to the East and West very generally has a rather neutral influence on the heat demand. North orientation is always a loss when looking at the heat demand.

The thermal quality of the window is decisive. Windows with moderate U-values might not reach positive energy balance in the coldest half of the year, even by South orientation.

Still keep in mind to use external shading to prevent extreme summer situations, and to consider daylight and view in the window design.

Heat recovery: The calculations showed that it is important to have the best possible heat recovery. To avoid freezing of the heat exchanger it is recommended in all Northern European climates to use a system to prevent the freezing. One of the possibilities is to use a ground-coupled heat exchanger (direct or indirect).

6.2 Single family house

Table 7 shows the summary of the main parts of the design values for a single family house (gross area appr. 172 m², $A_{\text{envelope}}/A = 2,4 \text{ m}^2/\text{m}^2$, $A_{\text{envelope}}/V = 0,74 \text{ m}^2/\text{m}^3$) when planning a very low energy house in different Northern European climates.

Table 7. Design rules and values for a single family house

	U-value opaque envelope	U-value glass	heat recovery	windows to south	windows to east/west	windows to north
	W/m ² K	W/m ² K	%	%	%	%
Jyväskylä	0,06 - 0,15	0,4 - 0,5	> 85	30-50	< 10	< 5
Oulu	0,06 - 0,15	0,4 - 0,5	> 85	30-50	< 10	< 5
Stockholm	0,11 - 0,18	0,5 - 0,6	> 85	40-60	< 20	< 5
Oslo	0,12 - 0,17	0,6 - 0,7	> 80	40-60	< 20	< 5
Tromso	0,06 - 0,15	0,4 - 0,5	> 85	30-50	< 10	< 5
Tallinn	0,10 - 0,17	0,4 - 0,5	> 85	40-60	< 20	< 5
Vilnius	0,10 - 0,17	0,4 - 0,5	> 85	40-60	< 20	< 5
Riga	0,10 - 0,17	0,4 - 0,5	> 85	40-60	< 20	< 5
Warsaw	0,11 - 0,19	0,5 - 0,6	> 85	40-60	< 20	< 5
Copenhagen	0,12 - 0,16	0,6 - 0,7	> 80	40-60	< 20	< 5

6.3 Apartment house

Table 8 shows the summary of the main parts of the design values for an apartment building (gross area appr. 2450 m², $A_{\text{envelope}}/A = 1,12 \text{ m}^2/\text{m}^2$, $A_{\text{envelope}}/V = 0,38 \text{ m}^2/\text{m}^3$) when planning a very low energy house in different Northern European climates. The building has 5 storeys.

Table 8. Design rules and values for an apartment building.

	U-value opaque envelope	U-value glass	heat recovery	windows to south	windows to east/west	windows to north
	W/m ² K	W/m ² K	%	%	%	%
Jyväskylä	0,08 - 0,15	0,4 - 0,5	> 80	30-50	< 10	< 5
Oulu	0,09 - 0,15	0,4 - 0,5	> 80	30-50	< 10	< 5
Stockholm	0,14 - 0,18	0,6 - 0,7	> 80	40-60	< 20	< 5
Oslo	0,16 - 0,17	0,6 - 0,7	> 75	40-60	< 20	< 5
Tromso	0,08 - 0,15	0,4 - 0,5	> 80	30-50	< 10	< 5
Tallinn	0,11 - 0,17	0,6 - 0,7	> 80	40-60	< 20	< 5
Vilnius	0,11 - 0,17	0,6 - 0,7	> 80	40-60	< 20	< 5
Riga	0,12 - 0,17	0,5 - 0,6	> 80	40-60	< 20	< 5
Warsaw	0,13 - 0,19	0,6 - 0,7	> 80	40-60	< 20	< 5
Copenhagen	0,16 - 0,17	0,6 - 0,8	> 75	40-60	< 20	< 5

7 CONCLUSIONS

7.1 Contribution to overall picture

In NorthPass report “Application of the local criteria/standards and their differences for very low-energy and low energy houses in the participating countries” the existing national building regulations and the existing low energy building definitions were compared as far as possible without calculating energy demand for sample buildings. That report did not take into account any regulations but simply gathered the existing experience and design rules for creating buildings with very low energy demands. On the basis of the existing design rules, selected parameter variations were calculated for two types of residential buildings: a single family house and an apartment building.

The calculation results, together with summaries from other existing works, resulted in relatively simple sets of design rules for all 10 studied locations in Northern Europe: Jyväskylä, Oulu, Stockholm, Oslo, Tromsø, Tallinn, Vilnius, Riga, Warsaw and Copenhagen.

7.2 Relation to the state-of-the-art and progress beyond it

This report is one of the very few existing – if not only – approaches to analyse and define quantitatively the applicable design rules for very low energy buildings in the Northern Europe. The purpose was to define a typical but also rather optimal overall building design as a basis for the parameter variation, which resulted primarily in target U-values and window orientation and size design.

In this report the optimization was technical, taking the climatic challenge into account. The optimal design and the target values, however, are a result of (life cycle) cost optimization. Nevertheless, the shown design values are based on solutions that should be simple to build and in this way also economically sustainable.

One objective of NorthPass project is to establish the technical background and guidelines for how to design very low energy houses in the Northern Europe. The analysis of this report does not include the cost optimisation or any other life cycle approaches, which will be tackled in upcoming NorthPass reports.

This report identifies some potential conflicts in building traditions and the basic design rules for very low energy houses, e.g. the recommended use of external blinds to avoid overheating in the summer. The barriers in “Application of the local criteria/standards and their differences for very low-energy and low energy houses in the participating countries” caused by diverging building regulations and standards in most of the Northern European countries are still valid when considering the recommended design rules. Also these need to be taken into consideration when planning the overcoming of the barriers to implementation of very low-energy houses identified.

8 REFERENCES

- [1] Peuhkuri, Ruut; Tschui, Adrian & Pedersen, Søren (2010). Application of the local criteria/standards and their differences for very low-energy and low energy houses in the participating countries. Northpass Deliverable D2. Project IEE/08/480/SI2.528386
 - [2] Ragonesi, Marco, Menti, Urs-Peter; Tschui, Adrian & Zurfluh, Benno (2009). Minergie-P. Das Haus der 2000-Watt-Gesellschaft. Faktor Verlag, Zürich.
 - [3] Pedersen, Søren (2008): Updated comparison of windows. Proceedings of 12th Internationale Passivhaustagung. April 2008. Nürnberg.
 - [4] PHPP Passivhaus Projektierungs Paket
 - [5] Eberhard Paul (2010). Luftqualität und Lüftungswärmeverluste bei 12 verschiedenen Lüftungsmethoden. Proceedings of 14th Internationale Passivhaustagung, May 2010. Dresden.
 - [6] Großklos, Marc: Optimierung der Verteilverluste und des Energieaufwandes für die Warmwasserbereitung bei Mehrfamilien-Passivhäusern; in: Tagungsband der Passivhaustagung, Mai 2010, Dresden, S. 179 – 184
 - [7] Jesper Kragh, Jørgen Rose, Svend Svendsen (2005). Mechanical ventilation with heat recovery in cold climates, Proceedings of 7th Symposium on Building Physics in the Nordic Countries. June 2005. Reykjavik.
 - [8] Carsten Rode, Jesper Kragh, Egil Borchersen, Petra Vladykova, Simon Furbo and Janne Dragsted (2009). Performance of the Low-energy House in Sisimiut. Proceedings of Cold Climate HVAC 2009. Sisimiut, Greenland, 2009
 - [9] http://erg.ucd.ie/pep/pdf/Passive_House_Sol_English.pdf
 - [10] Thomas Boermans & Carsten Petersdorff et.al (2007) U-values for better energy performance of buildings. Ecofys Germany for EURIMA.
 - [11] Jyri Nieminen, Riikka Holopainen and Kimmo Lylykangas (2008). Passive House for a cold climate. Proceedings of 8th Symposium on Building Physics in the Nordic Countries. June 2008. Copenhagen
 - [12] Beck, Edgar (1996). Wärmerückgewinnung aus schadstoffbelasteter Fortluft. In: HLH 1996, part 10, page 32. VDI-Verlag Düsseldorf. (English translation: "Heat Recovery from Exhaust Air" is published by Hoval: Vaduz. Download: http://www.hoval.com/docs/Waermerueck_pdf/Heat_Recovery_from_Exhaust_Air.pdf)
 - [13] Wolfgang Feist, Andreas Gerber, Tilmann Kuhn, Jürgen Schnieders (1999). Passivhaus Sommerfall, Protokollband Nr. 15. Arbeitskreis kostengünstige Passivhäuser Phase II. Passivhaus Institut, 1999.
 - [14] Camilla Brunsgaard, Tine S. Larsen, Per Heiselberg og Mary-Ann Knudstrup (2010). Kvantitativ og kvalitativ evaluering af indeklimaet i Komfort Husene. Proceedings of 3rd Passivhus Norden Conference. October 2010. Aalborg.
 - [15] VTT (2007) Talonrakennuksen routasuojausohjeet (in Finnish: Frost-heave protection of buildings). Rakennustieto Oy. 2007
 - [16] SIA (2002): Gebäude mit hohem Glasanteil – Behaglichkeit und Energieeffizienz. SIA Schweizerischer Ingenieur- u. Architektenverein. Dokumentation 176.
-

[17] Claus Kahlert, Rosemarie Hellmann, Olaf Hildebrandt, Thomas Kirtschig, Ulrich Rochard (2004). Wirtschaftlichkeit energiesparenden Bauens für kommunale Gebäude in Heidelberg. Stadt Heidelberg, Amt für Umweltschutz, Energie und Gesundheitsförderung. Ebök.

9 APPENDICES

9.1 Windows area ratio

The following appendix shows the calculated space heat demand in dependency of the windows size (ratio to the façade) and the orientation. The calculations are based on EN 13790:2008 and are performed for a building with the size of a single family house. There are for every climate two calculations:

- one without any other windows on the other façades and
- one with the a varying window size and constant window areas to the other façades: N=1%, E=6%, S=54% and W=6%.

9.1.1 Jyväskylä

North:

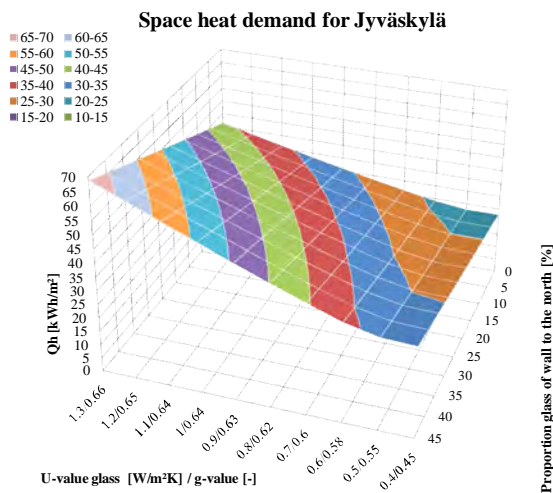

East:

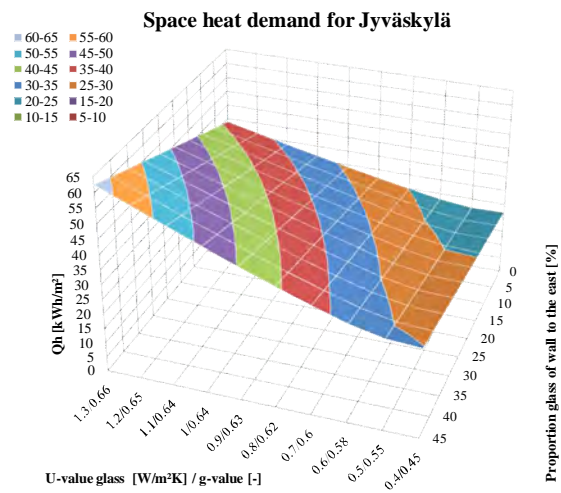

South:

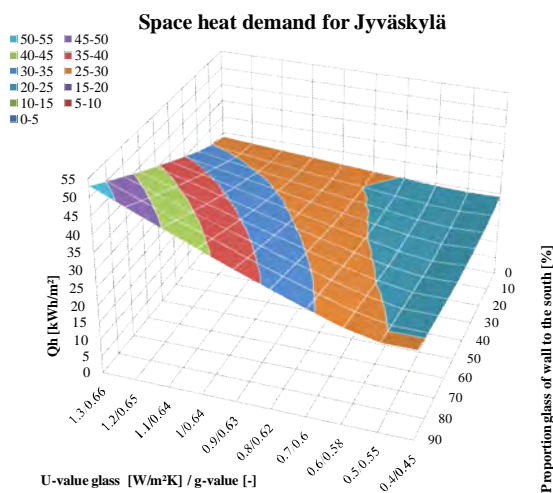

West:

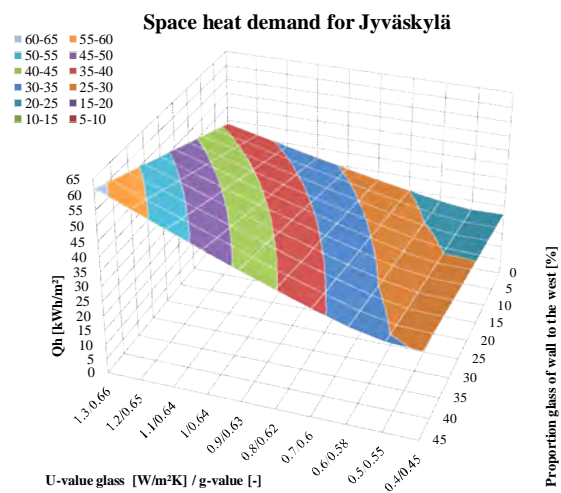
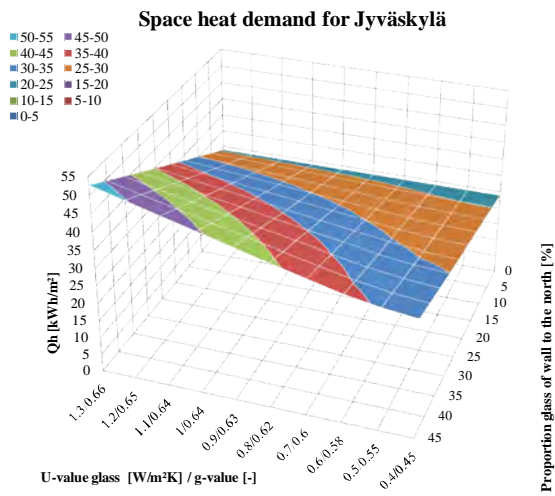
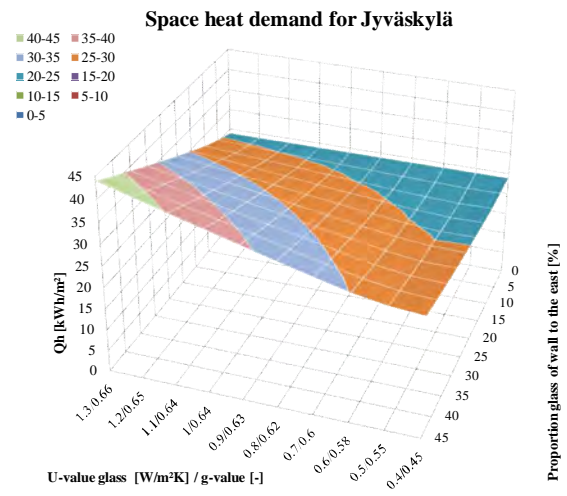

Figure 61. Effect of different window U-values (linked with the g-values) and different glass proportions on the given façade on the space heating demand in Jyväskylä. Fixed window size to every other orientation: N=1%, E=6%, S=54% and W=6%.

North:



East:



South:

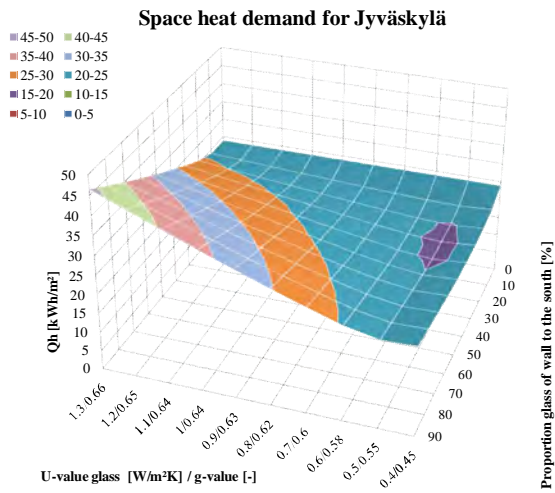

West:

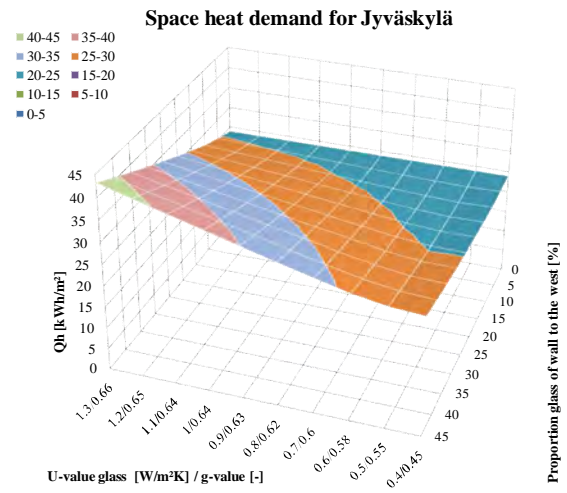
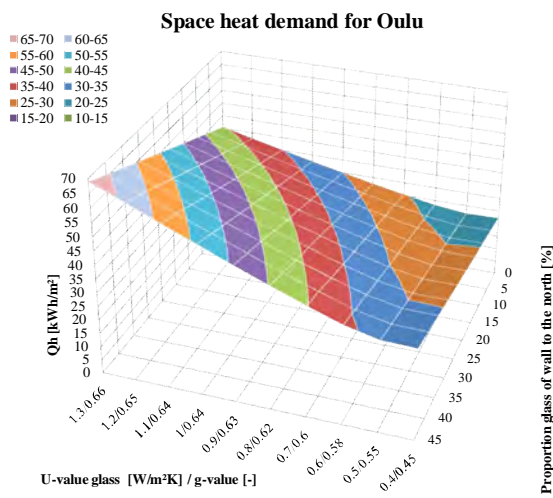

Figure 62. Effect of different window U-values (linked with the g-values) and different glass proportions on the given façade on the space heating demand in Jyväskylä. No windows to other directions.

9.1.2 Oulu

North:



East:

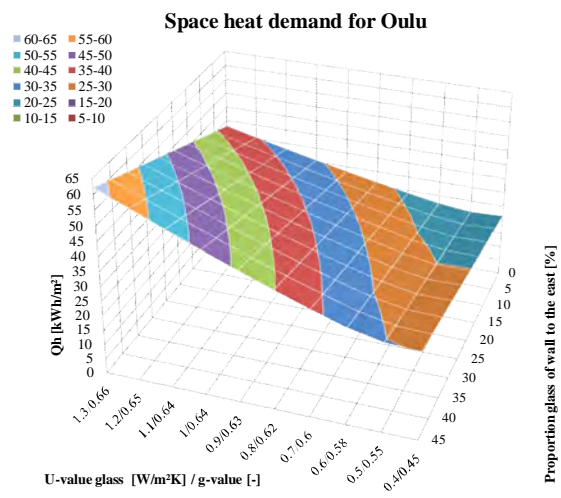

South:

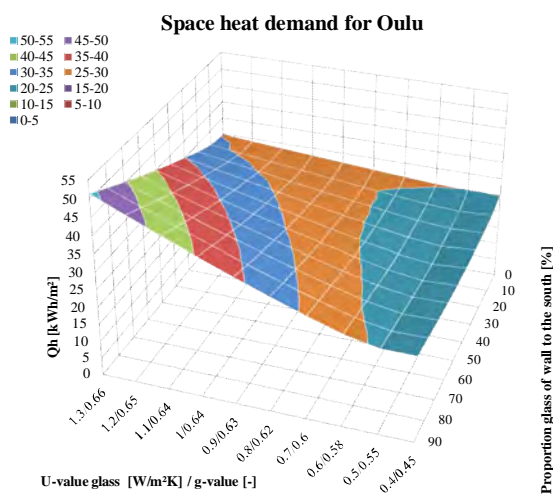

West:

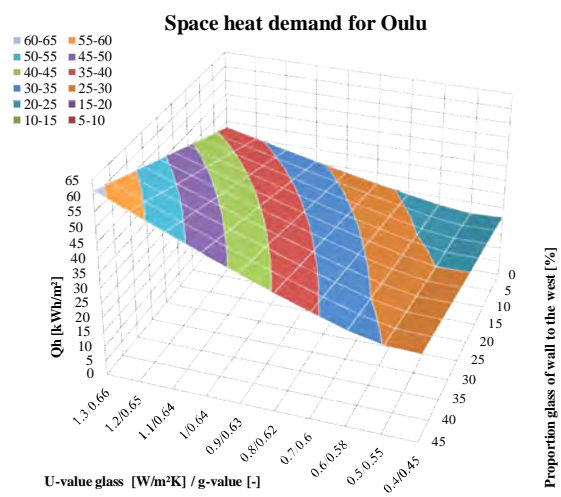
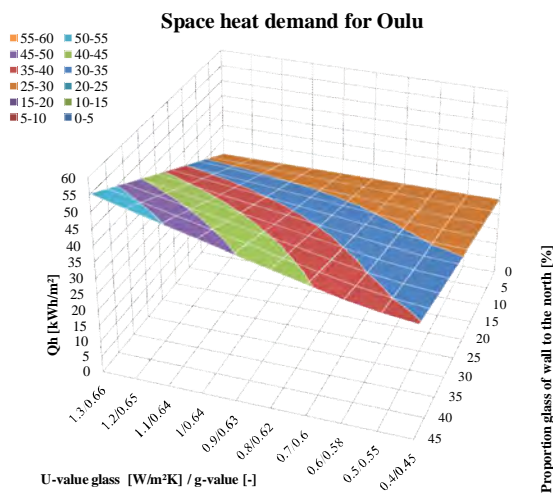
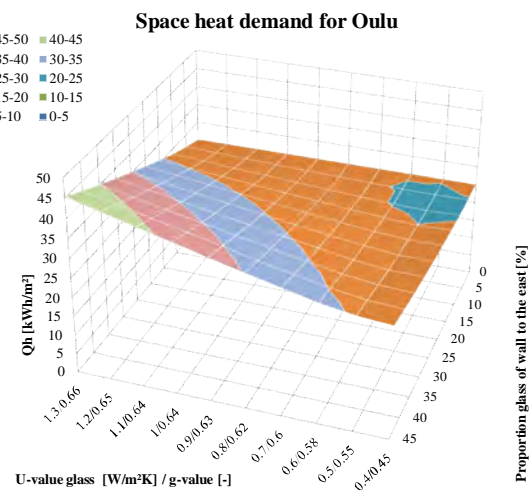

Figure 63. Effect of different window U-values (linked with the g-values) and different glass proportions on the given façade on the space heating demand in Oulu. Fixed window size to every other orientation: N=1%, E=6%, S=54% and W=6%.

North:



East:



South:

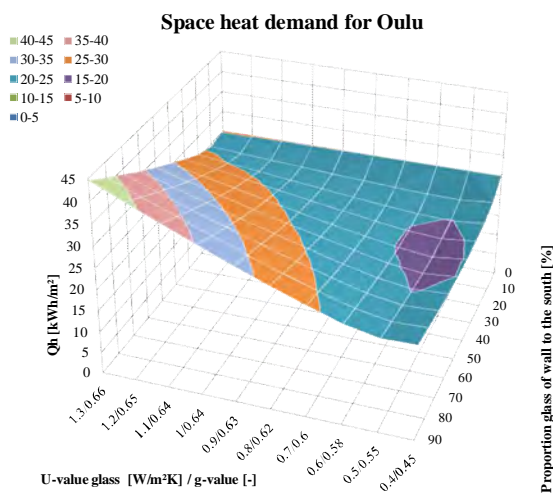

West:

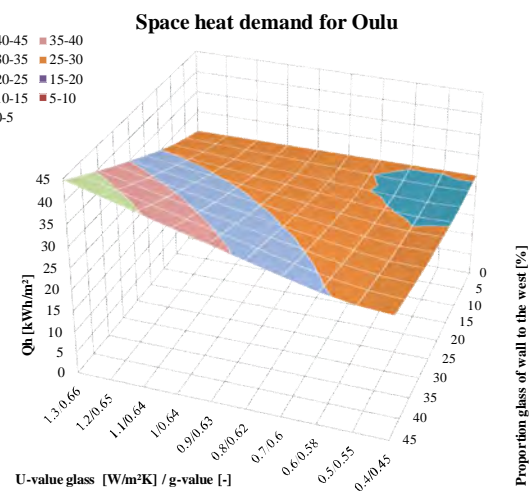
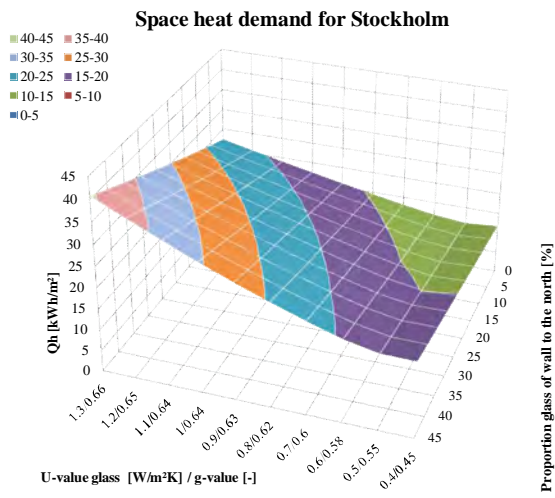

Figure 64. Effect of different window U-values (linked with the g-values) and different glass proportions on the given façade on the space heating demand in Oulu. No windows to other directions.

9.1.3 Stockholm

North:



East:

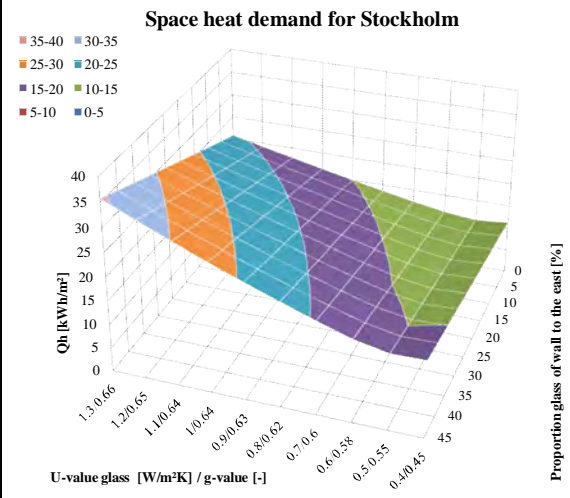

South:

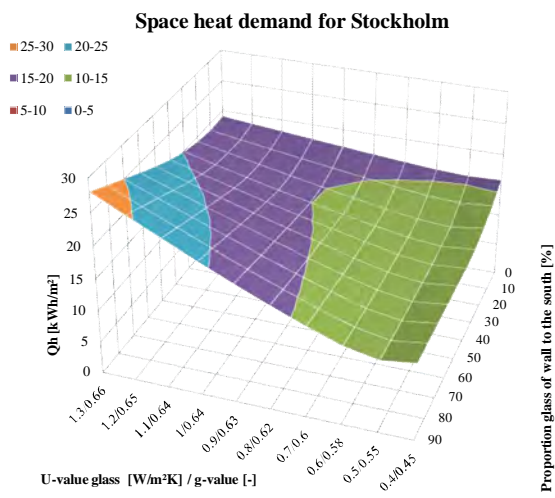

West:

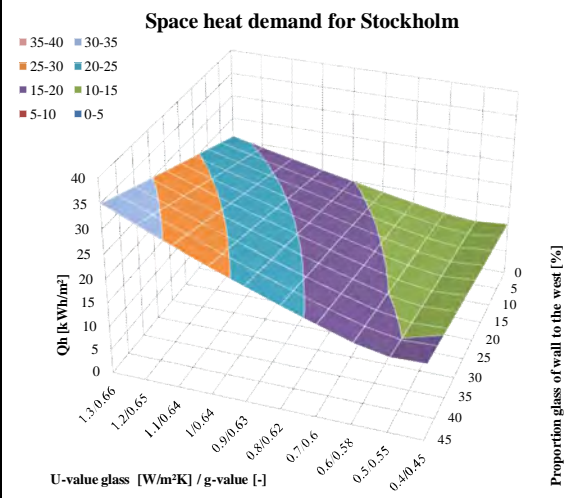
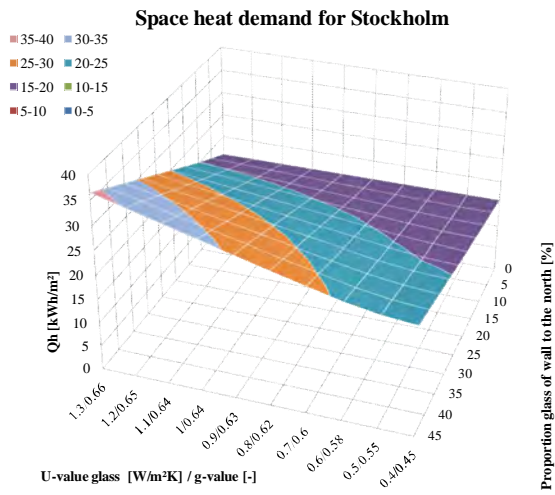
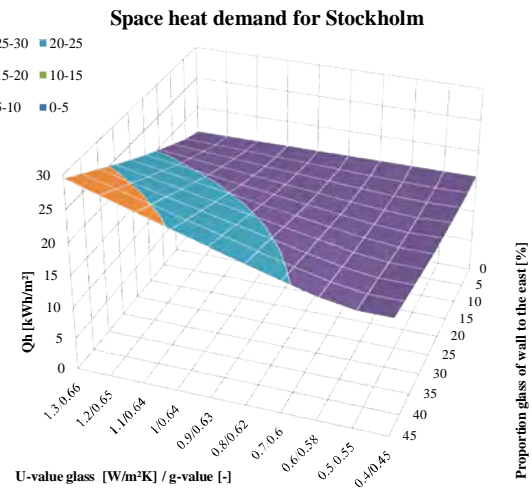

Figure 65. Effect of different window U-values (linked with the g-values) and different glass proportions on the given façade on the space heating demand in Stockholm. Fixed window size to every other orientation: N=1%, E=6%, S=54% and W=6%.

North:



East:



South:

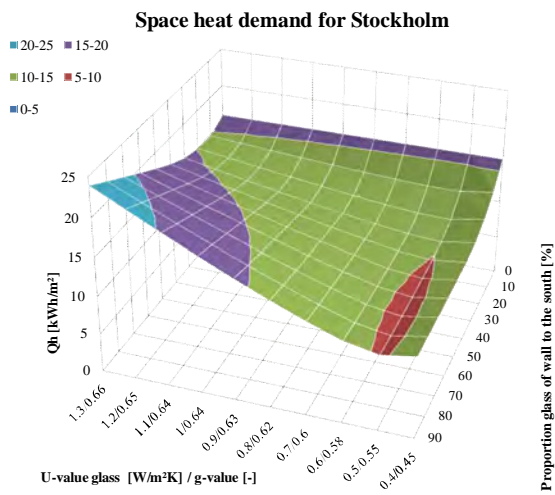

West:

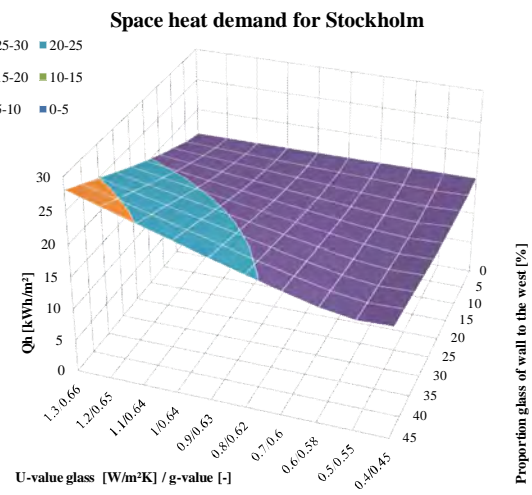
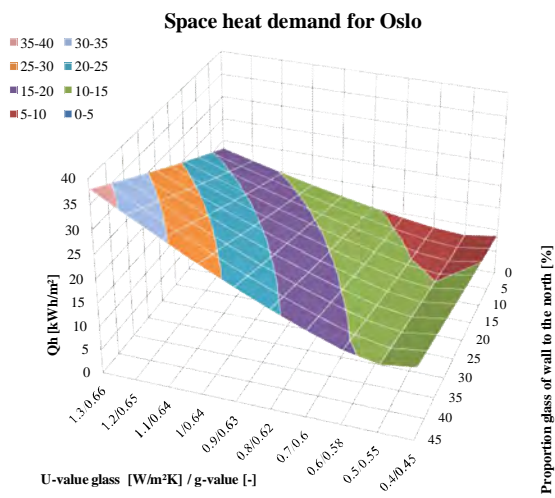

Figure 66. Effect of different window U-values (linked with the g-values) and different glass proportions on the given façade on the space heating demand in Stockholm. No windows to other directions.

9.1.4 Oslo

North:



East:

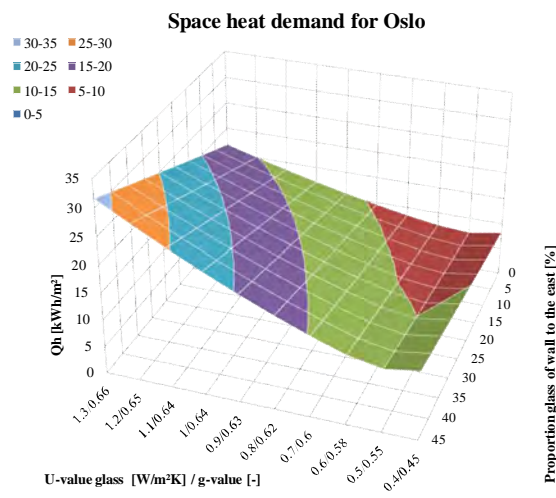

South:

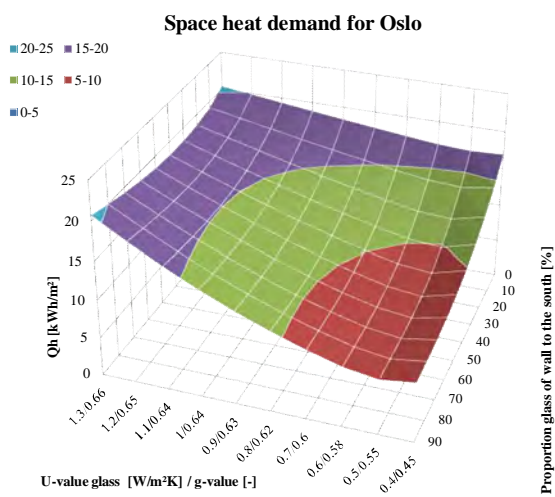

West:

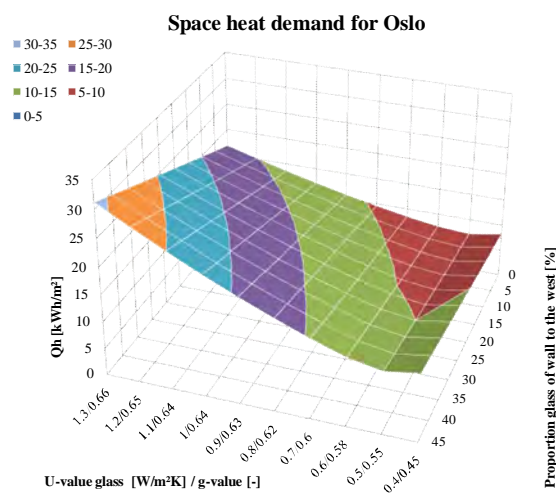
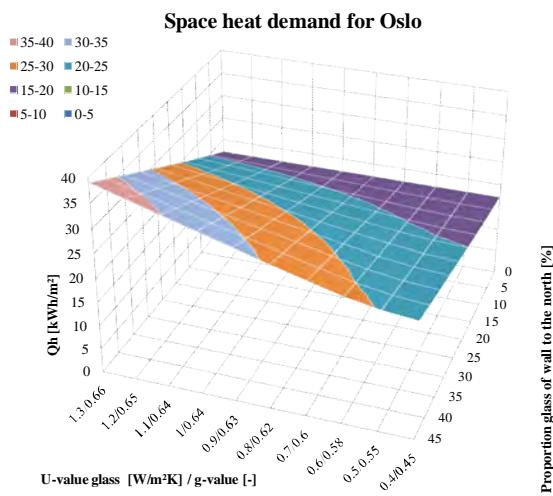
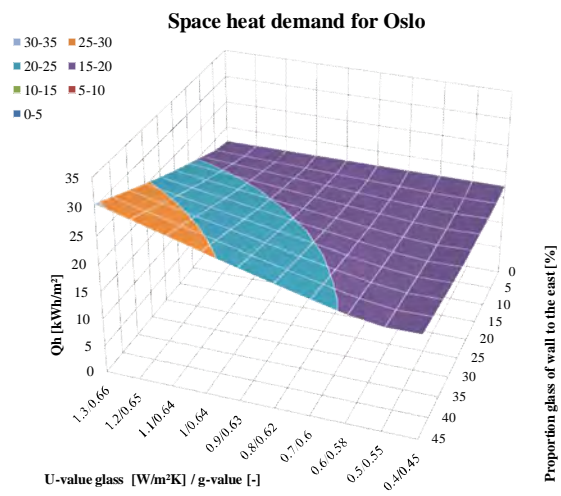

Figure 67. Effect of different window U-values (linked with the g-values) and different glass proportions on the given façade on the space heating demand in Oslo. Fixed window size to every other orientation: N=1%, E=6%, S=54% and W=6%.

North:



East:



South:

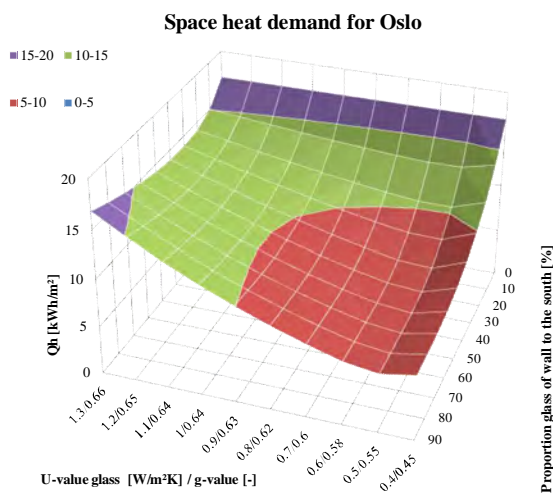

West:

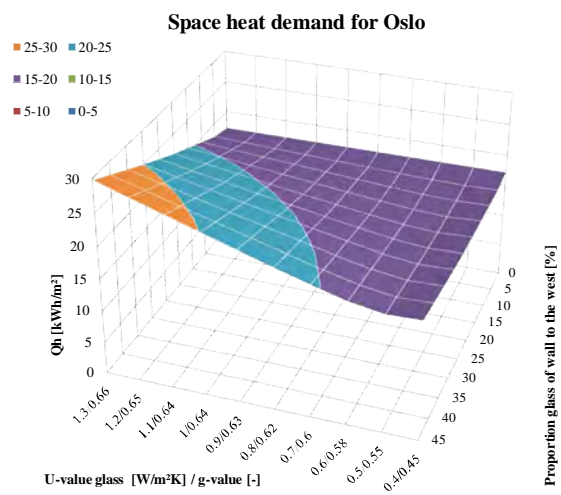
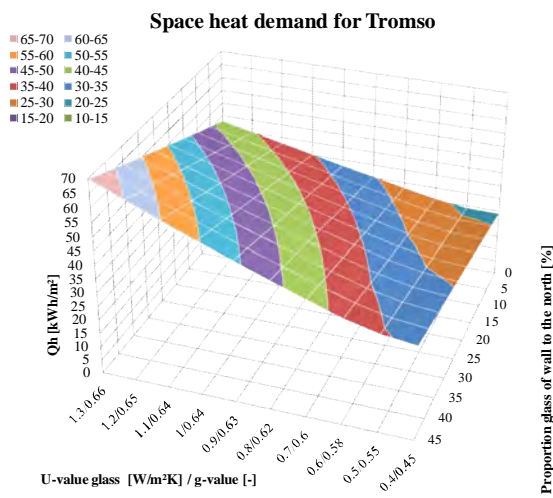

Figure 68. Effect of different window U-values (linked with the g-values) and different glass proportions on the given façade on the space heating demand in Oslo. No windows to other directions.

9.1.5 Tromsø

North:



East:

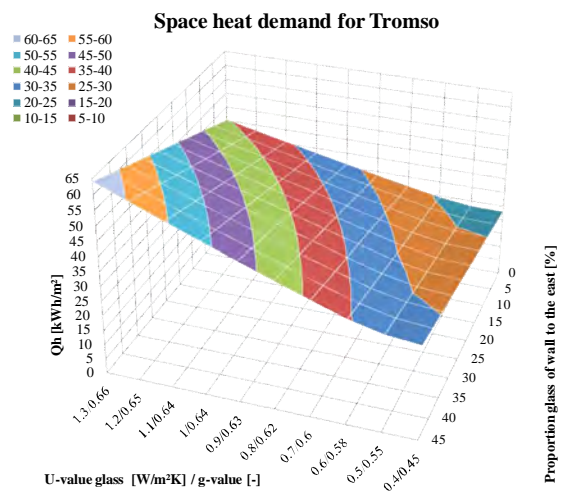

South:

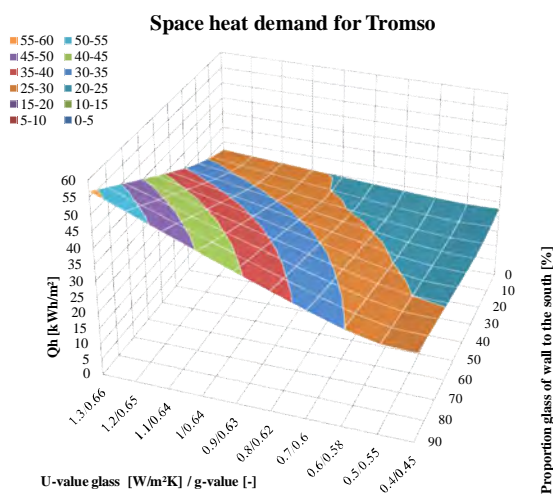

West:

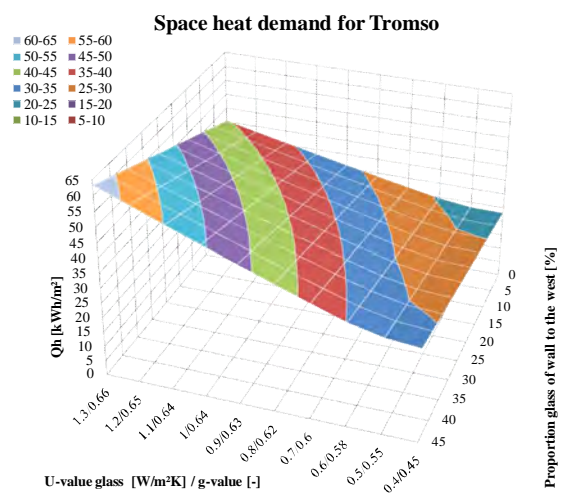
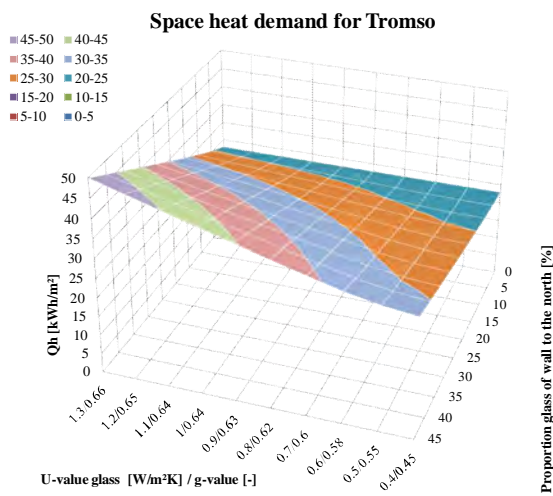
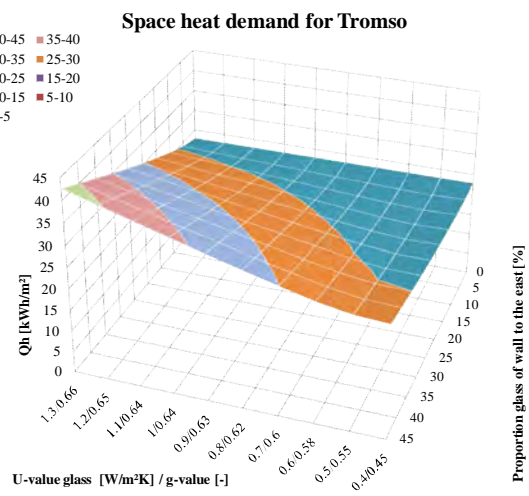

Figure 69 Effect of different window U-values (linked with the g-values) and different glass proportions on the given façade on the space heating demand in Tromsø. Fixed window size to every other orientation: N=1%, E=6%, S=54% and W=6%..

North:



East:



South:

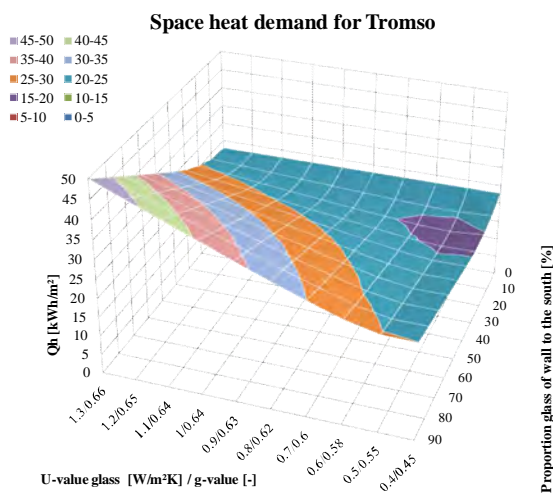

West:

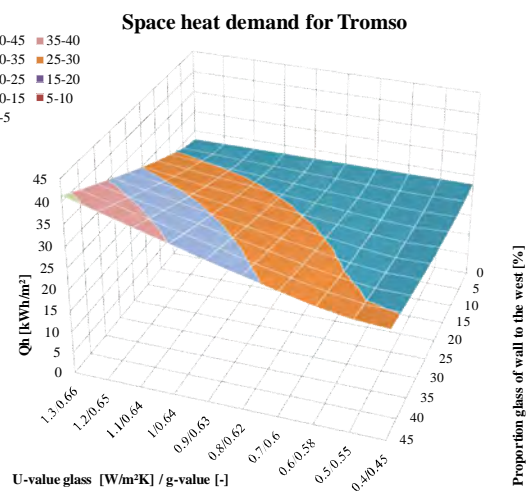
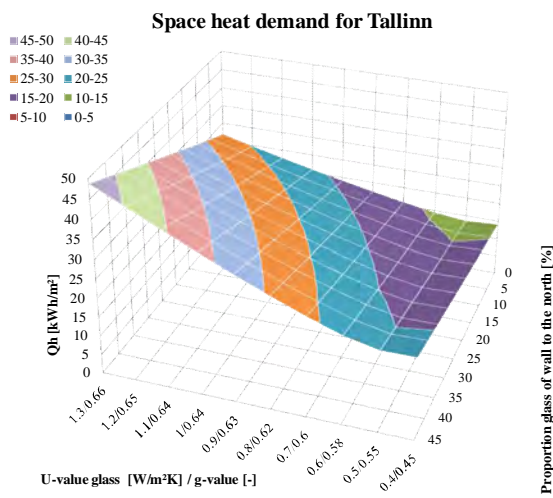

Figure 70. Effect of different window U-values (linked with the g-values) and different glass proportions on the given façade on the space heating demand in Tromsø. No windows to other directions.

9.1.6 Tallinn

North:



East:

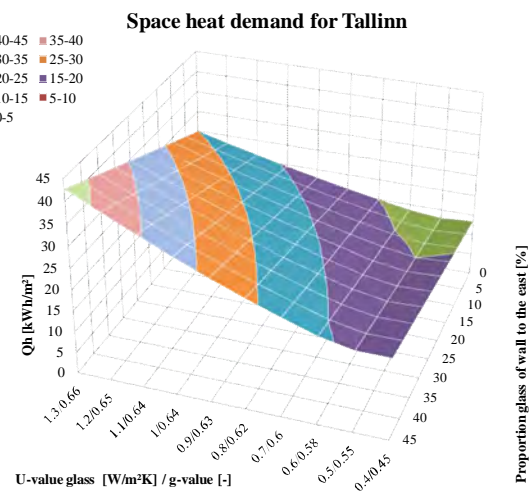

South:

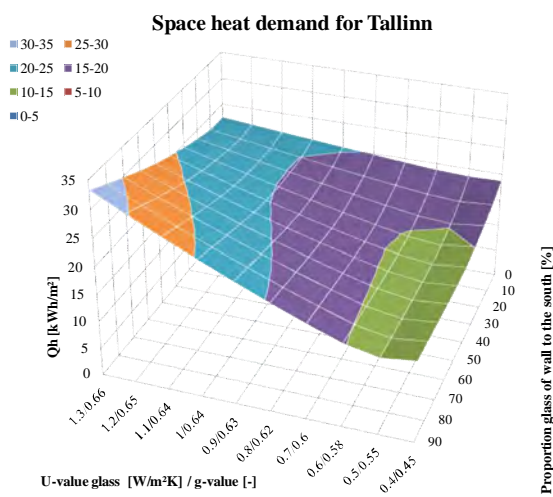

West:

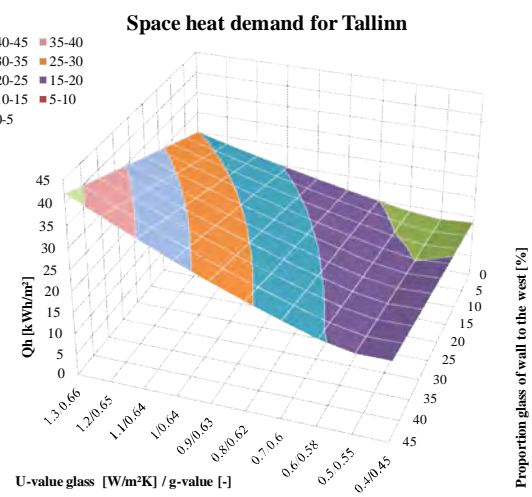
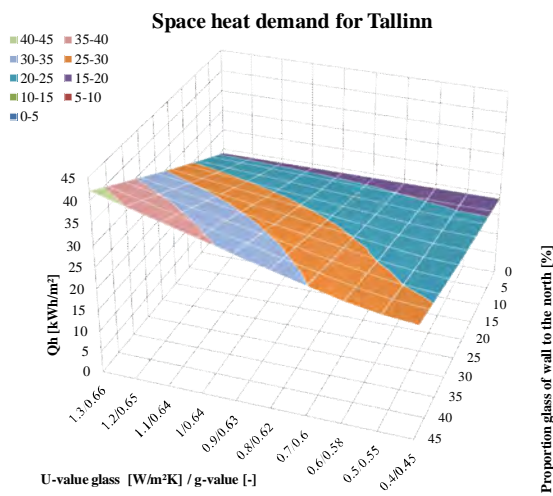
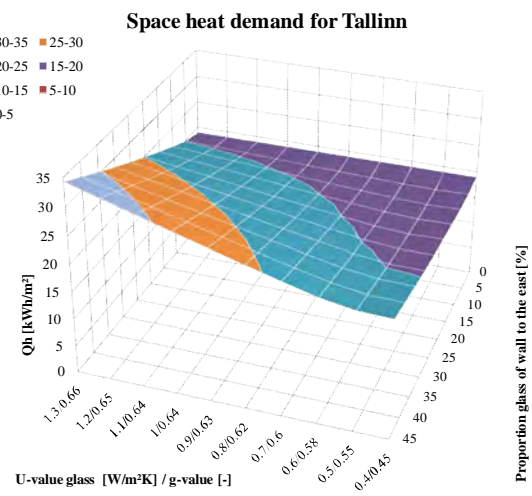

Figure 71. Effect of different window U-values (linked with the g-values) and different glass proportions on the given façade on the space heating demand in Tallinn. Fixed window size to every other orientation: N=1%, E=6%, S=54% and W=6%.

North:



East:



South:

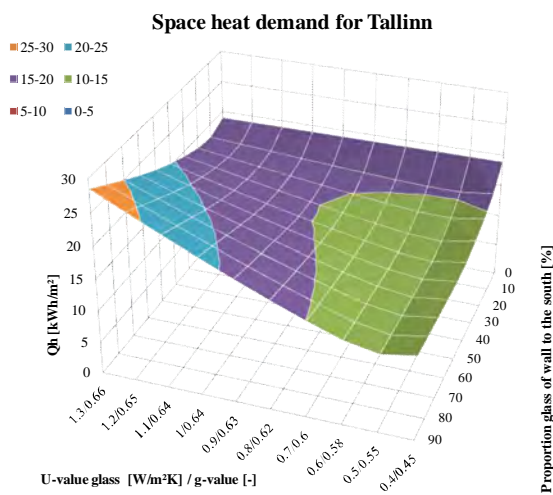

West:

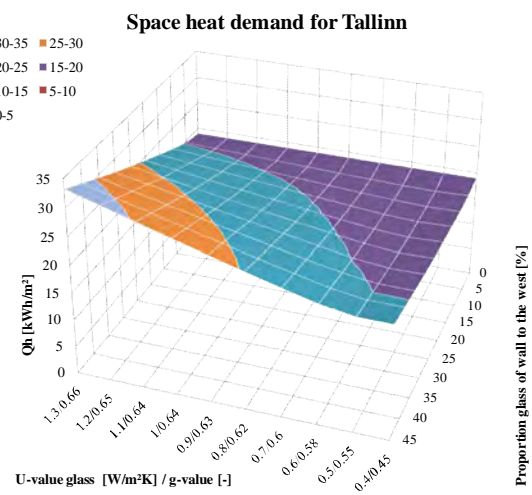
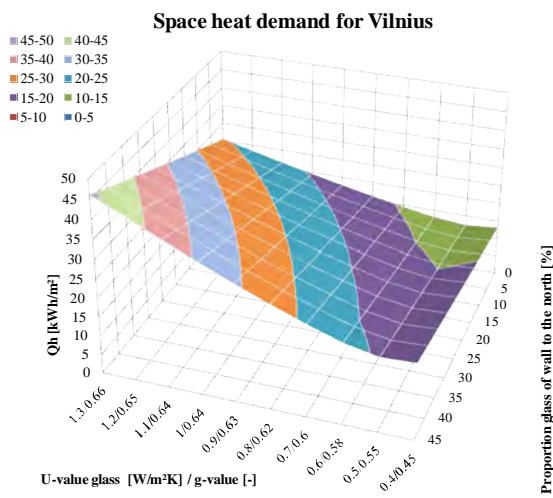

Figure 72 Effect of different window U-values (linked with the g-values) and different glass proportions on the given façade on the space heating demand in Tallinn. No windows to other directions..

9.1.7 Vilnius

North:



East:

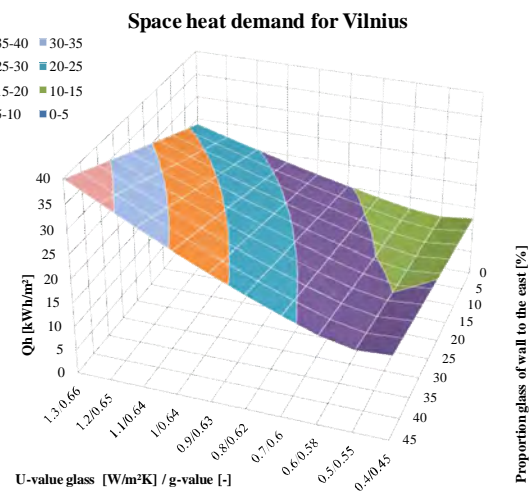

South:

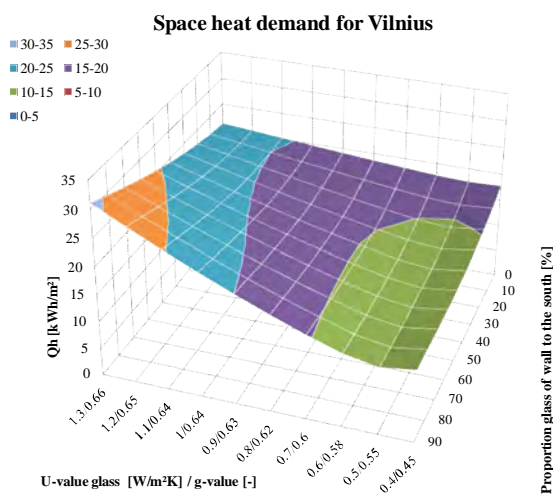

West:

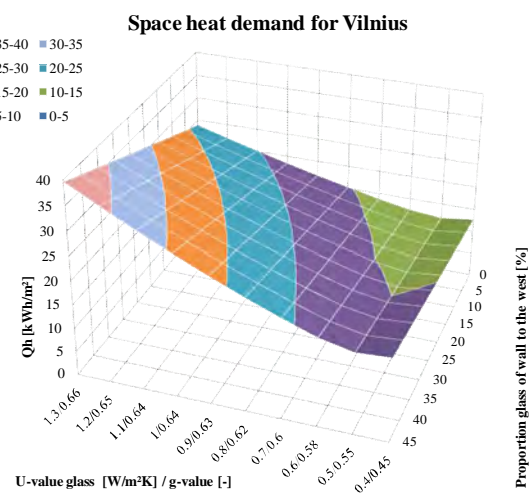
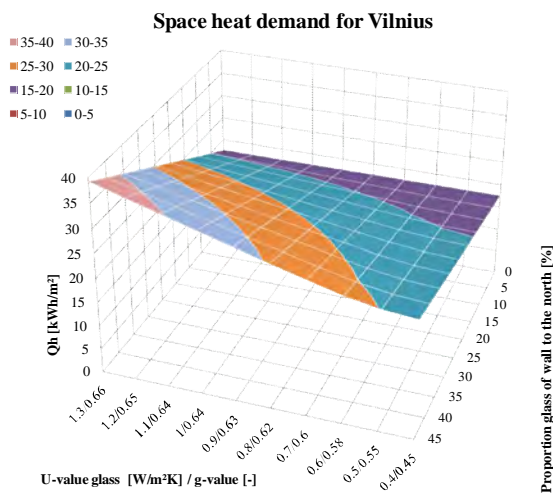
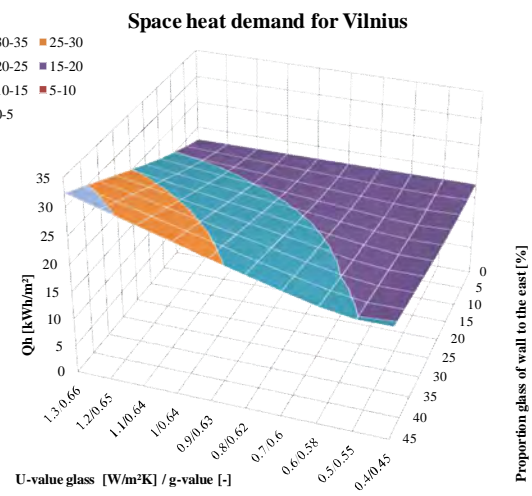

Figure 73. Effect of different window U-values (linked with the g-values) and different glass proportions on the given façade on the space heating demand in Vilnius. Fixed window size to every other orientation: N=1%, E=6%, S=54% and W=6%.

North:



East:



South:

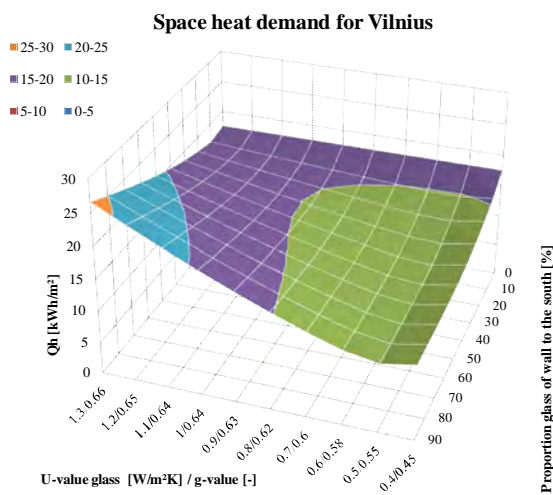

West:

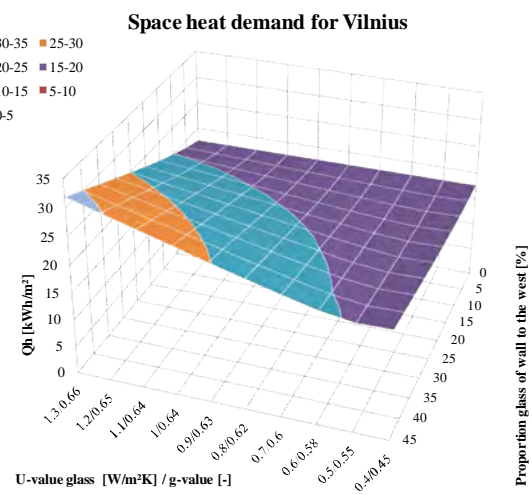
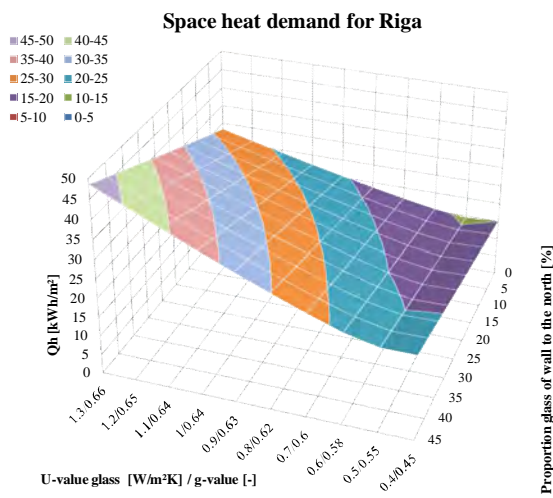

Figure 74. Effect of different window U-values (linked with the g-values) and different glass proportions on the given façade on the space heating demand in Vilnius. No windows to other directions..

9.1.8 Riga

North:



East:

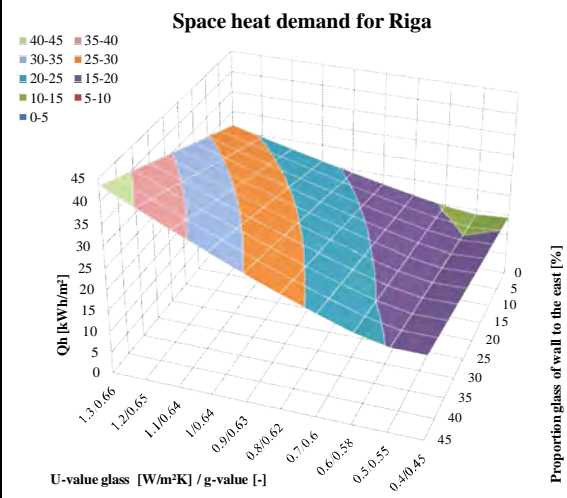

South:

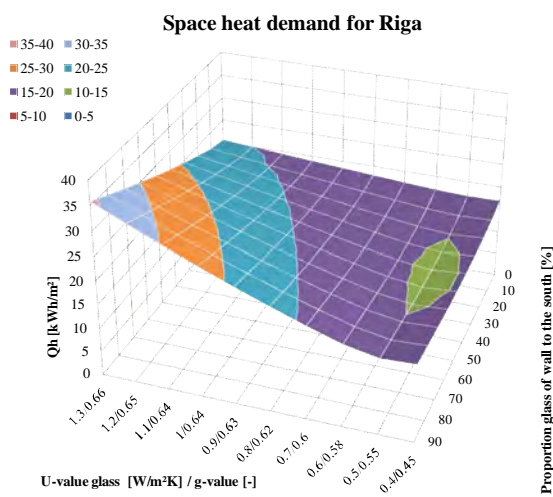

West:

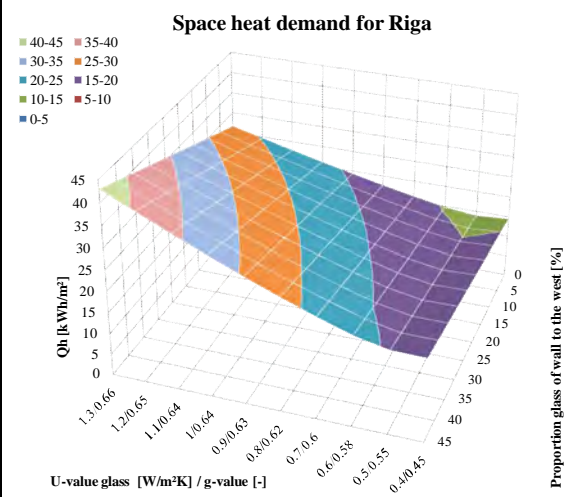
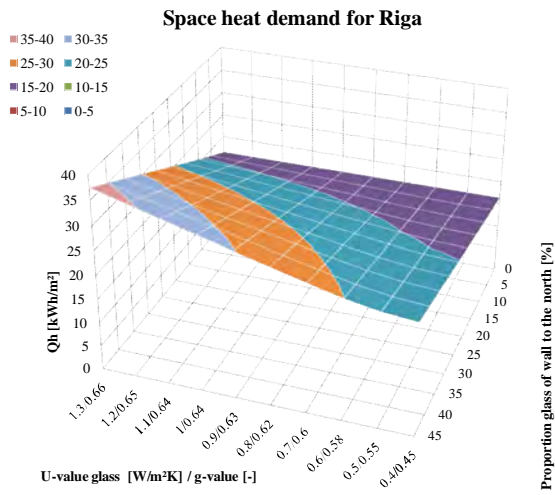
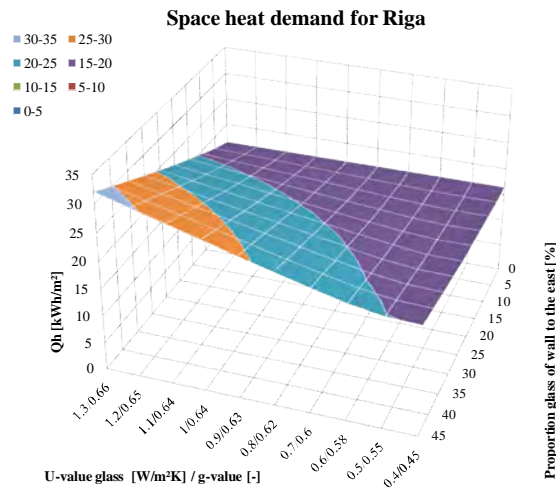

Figure 75. Effect of different window U-values (linked with the g-values) and different glass proportions on the given façade on the space heating demand in Riga. Fixed window size to every other orientation: N=1%, E=6%, S=54% and W=6%.

North:



East:



South:

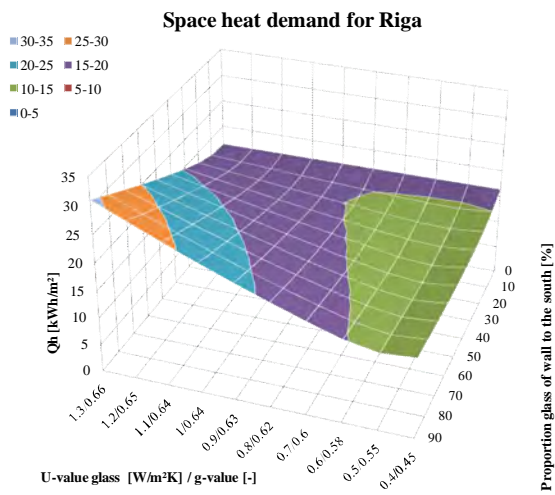

West:

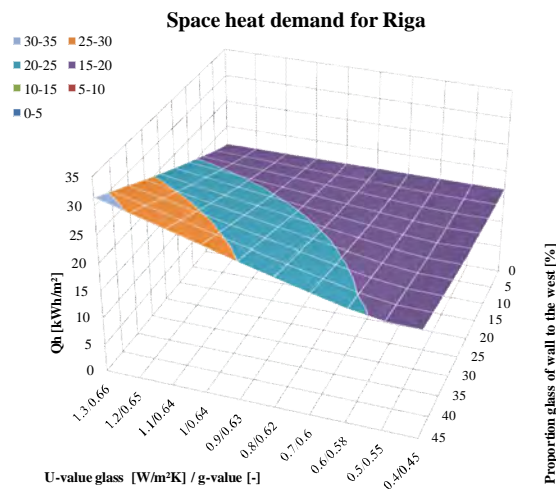
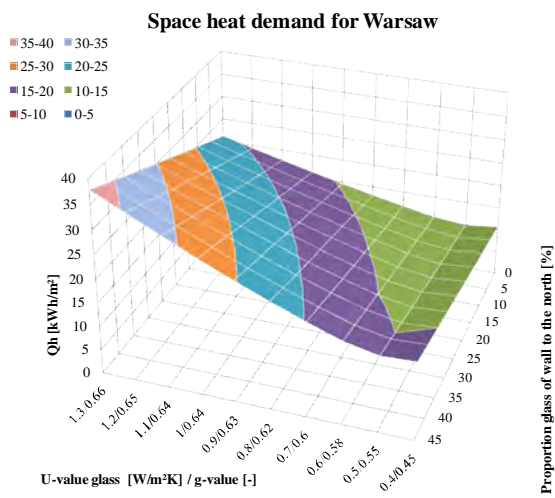

Figure 76 Effect of different window U-values (linked with the g-values) and different glass proportions on the given façade on the space heating demand in Riga. No windows to other directions.

9.1.9 Warsaw

North:



East:

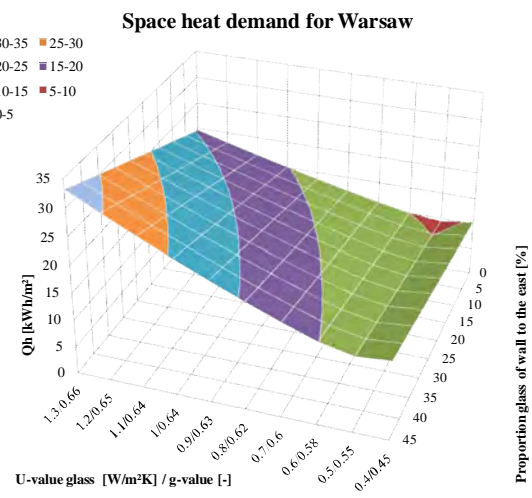

South:

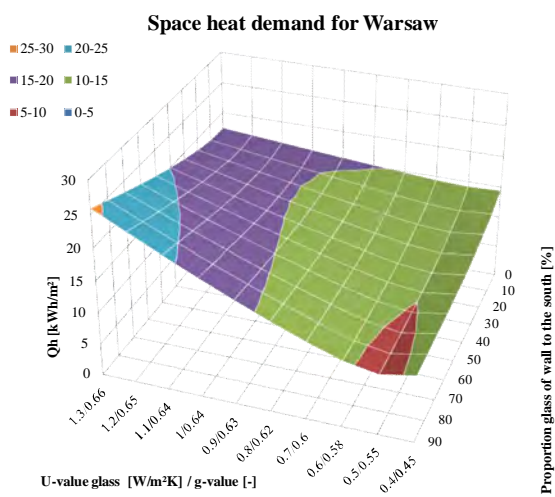

West:

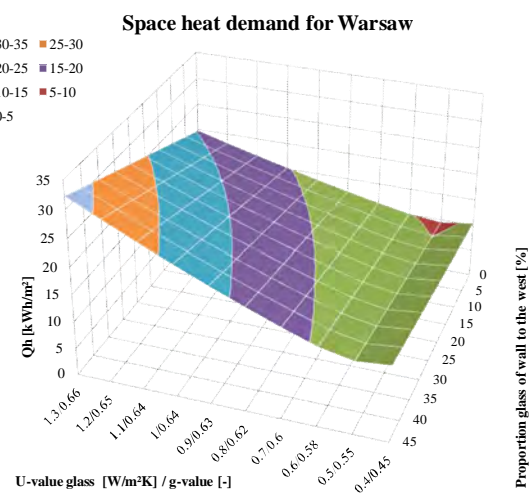
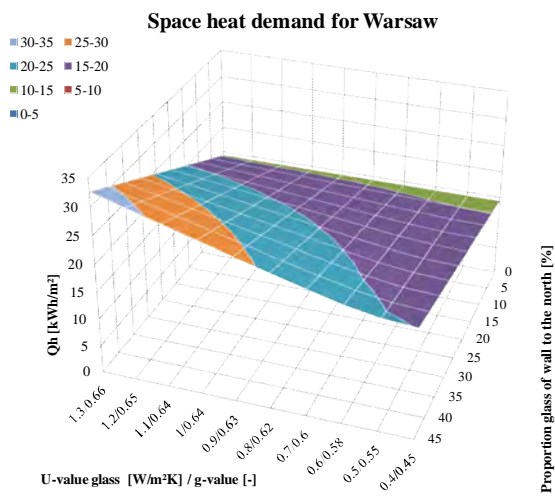
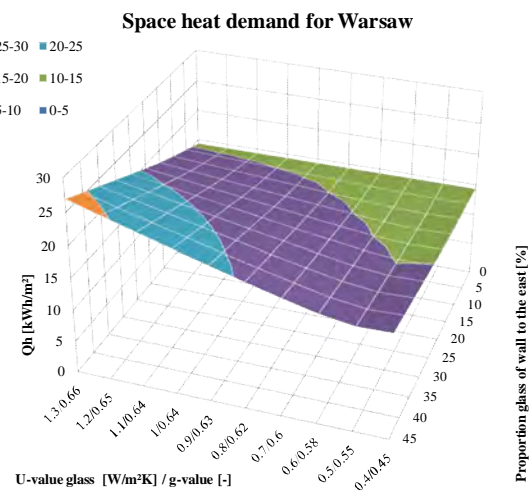

Figure 77. Effect of different window U-values (linked with the g-values) and different glass proportions on the given façade on the space heating demand in Warsaw. Fixed window size to every other orientation: N=1%, E=6%, S=54% and W=6%.

North:



East:



South:

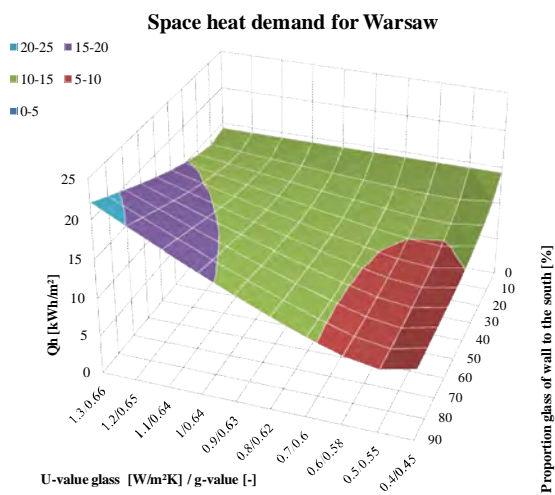

West:

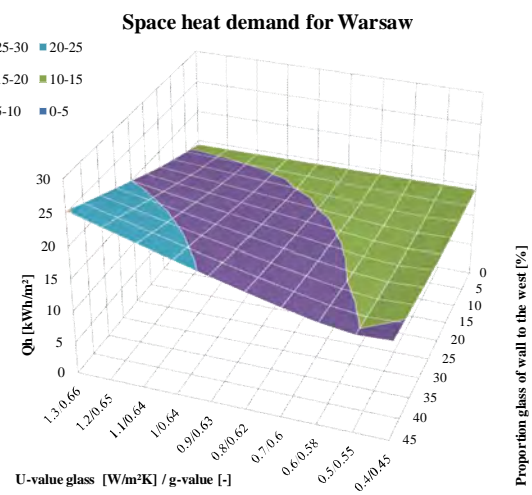
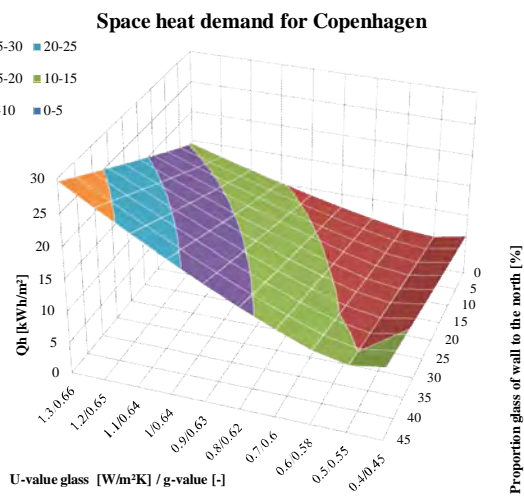

Figure 78. Effect of different window U-values (linked with the g-values) and different glass proportions on the given façade on the space heating demand in Warsaw. No windows to other directions.

9.1.10 Copenhagen

North:



East:

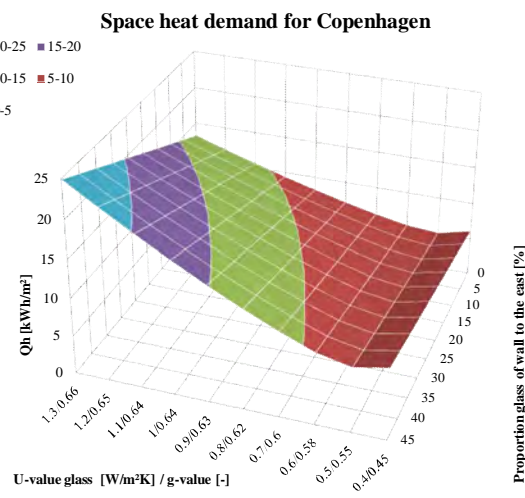

South:

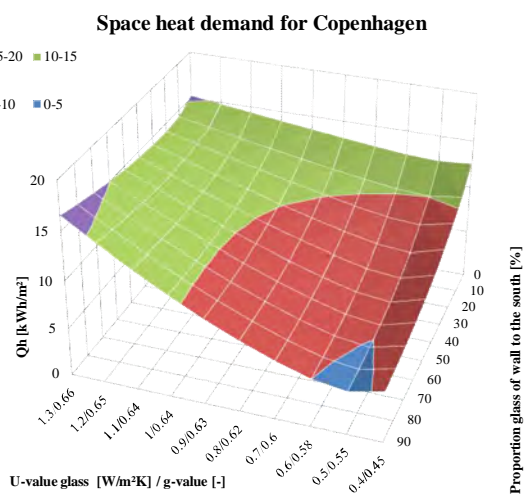

West:

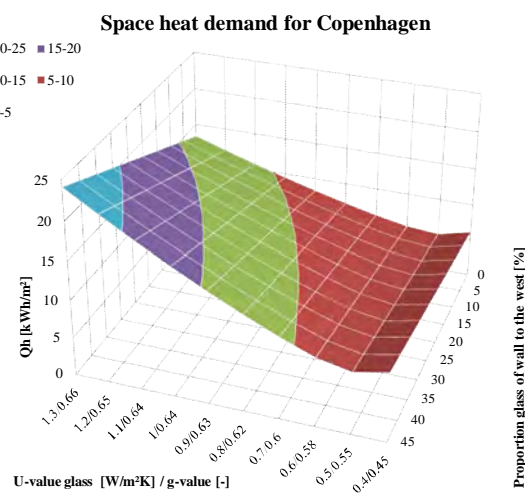
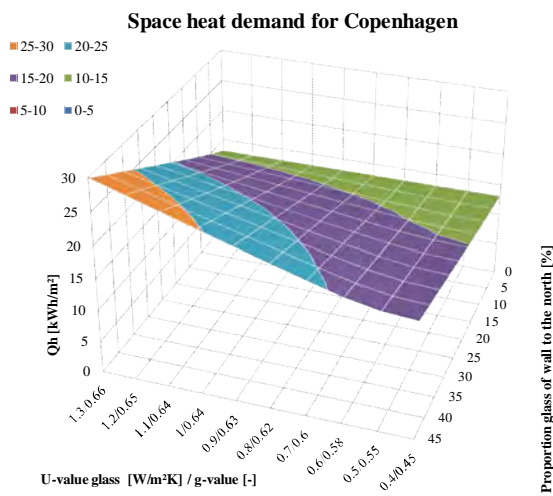
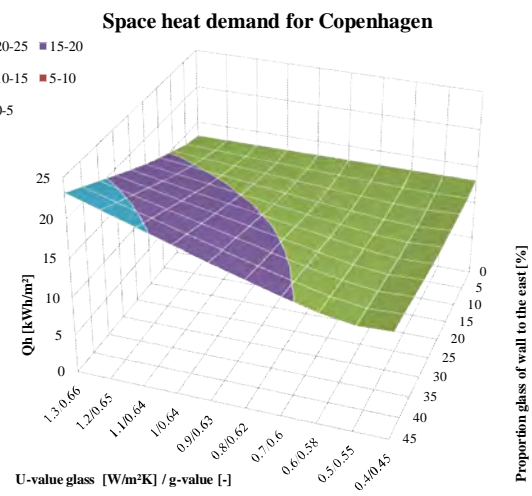

Figure 79. Effect of different window U-values (linked with the g-values) and different glass proportions on the given façade on the space heating demand in Copenhagen. Fixed window size to every other orientation: N=1%, E=6%, S=54% and W=6%.

North:



East:



South:

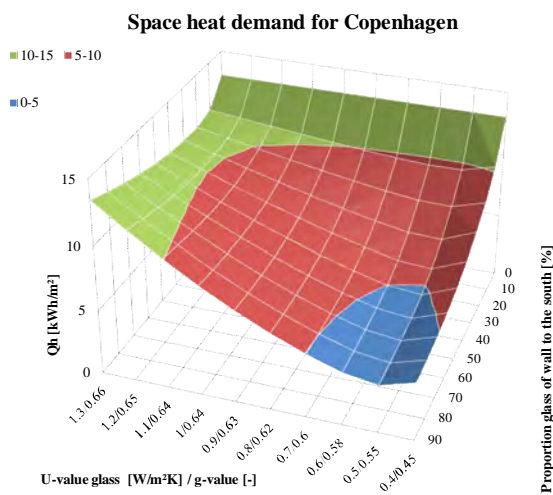

West:

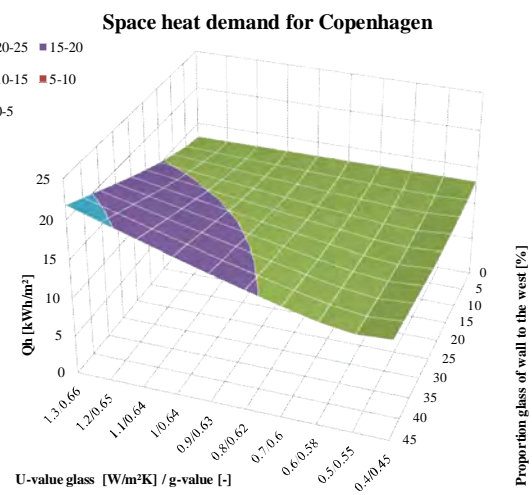

Figure 80. Effect of different window U-values (linked with the g-values) and different glass proportions on the given façade on the space heating demand in Copenhagen. No windows to other directions.